

2008

# Computer aided process planning for rapid prototyping using a genetic algorithm

Alex Renner

Iowa State University

Follow this and additional works at: <https://lib.dr.iastate.edu/rtd>



Part of the [Industrial Engineering Commons](#)

## Recommended Citation

Renner, Alex, "Computer aided process planning for rapid prototyping using a genetic algorithm" (2008). *Retrospective Theses and Dissertations*. 15376.

<https://lib.dr.iastate.edu/rtd/15376>

This Thesis is brought to you for free and open access by the Iowa State University Capstones, Theses and Dissertations at Iowa State University Digital Repository. It has been accepted for inclusion in Retrospective Theses and Dissertations by an authorized administrator of Iowa State University Digital Repository. For more information, please contact [digirep@iastate.edu](mailto:digirep@iastate.edu).

**Computer aided process planning for rapid prototyping using a genetic algorithm**

by

**Alex Renner**

A thesis submitted to the graduate faculty  
in partial fulfillment of the requirements for the degree of

**MASTER OF SCIENCE**

Co-Majors: Industrial Engineering;  
Human Computer Interaction

Program of Study Committee:  
Matthew C. Frank, Co-Major Professor  
Eliot H. Winer, Co-Major Professor  
Frank E. Peters

Iowa State University

Ames, Iowa

Copyright © Alex Renner, 2008. All rights reserved.

UMI Number: 1454594

### INFORMATION TO USERS

The quality of this reproduction is dependent upon the quality of the copy submitted. Broken or indistinct print, colored or poor quality illustrations and photographs, print bleed-through, substandard margins, and improper alignment can adversely affect reproduction.

In the unlikely event that the author did not send a complete manuscript and there are missing pages, these will be noted. Also, if unauthorized copyright material had to be removed, a note will indicate the deletion.



---

UMI Microform 1454594  
Copyright 2008 by ProQuest LLC  
All rights reserved. This microform edition is protected against  
unauthorized copying under Title 17, United States Code.

---

ProQuest LLC  
789 East Eisenhower Parkway  
P.O. Box 1346  
Ann Arbor, MI 48106-1346

## Table of Contents

List of Figures .....	iii
List of Tables .....	v
Abstract .....	vi
1 Introduction .....	1
1.1 Computer Aided Process Planning (CAPP) .....	1
1.2 Motivation .....	3
1.3 Objective .....	5
2 Literature Review .....	8
2.1 CNC-RP Overview .....	8
2.2 Hybrid RP Systems for Metals .....	9
2.3 Hybrid Methods .....	10
2.4 Accessibility Analysis .....	12
2.5 Tool and Machining Orientation Sequencing .....	14
2.6 Summary .....	17
3 Overview of Solution Methodology .....	19
3.1 Background .....	19
3.2 An improved process planning algorithm .....	22
3.2.1 Adapting Visibility for Thin Web Avoidance .....	23
3.2.2 Tool Accessibility, Selection and Machining Time calculations .....	26
3.3 Genetic Algorithm Methodology .....	27
3.4 Summary .....	29
4 Solution Approach .....	30
4.1 An improved process planning algorithm .....	30
4.1.1 Adapting Visibility Analysis for Thin Web Avoidance .....	31
4.1.2 Tool Accessibility, Selection and Machining Time calculations .....	39
4.2 Genetic Algorithm .....	50
4.3 Implementation .....	55
5 Discussion, Future Work, and Conclusions .....	62
5.1 Discussion .....	62
5.2 Future Work .....	66
5.3 Conclusions .....	67
Acknowledgements .....	68
References .....	69

## List of Figures

Figure 3-1: Subtractive Rapid Prototyping, (a) Steps of the Process [Frank, et al. 2006]  
(b) Finished part created with SRP

Figure 3-2: Current machining orientations, max and min depths shown for first orientation

Figure 3-3: Machining simulation at  $180^\circ$  after  $0^\circ$  was machined

Figure 4-1: Sample part illustrating visibility analysis (a) Isometric view of example part with axis of rotation (b) Right side view showing Finishing Angles output by VISI

Figure 4-2: Machining operations generating a Thin Web [Frank, 2003]

Figure 4-3: Example part illustrating extra angles to avoid thin webs

Figure 4-4: Illustration of adjusted thin web avoidance method

Figure 4-5: Example part at three machining orientations (a)  $0^\circ$ , (b)  $130^\circ$ , and (c)  $270^\circ$

Figure 4-6: Setup orientations with and without providing an initial angle to VISI

Figure 4-7: Tool Access Volume (TAV) method [Lim 2001]

Figure 4-8: Analyzing Polygon segments to find Scallop Area

Figure 4-9: Applying TAV to layer based machining [Lin & Gian, 1999]

Figure 4-10: (a) Isometric view of part, tool, and inaccessible feature  
(b) View of inaccessible volume from the right side of the part

Figure 4-11: Example part viewed from right side showing slicing

Figure 4-12: RDVC vs. Tool Diameter [graph based on Lim et. al., 2000].

Figure 4-13: Different Scallop areas left by different sized tools

Figure 4-14: Example graph highlighting multiple local minima

Figure 4-15: Test parts

Figure 4-16: Orientations for Proposed Approach are dotted and values are given. Compare to current CNC-RP orientations.

Figure 5-1: Features affecting tool accessibility

Figure 5-2: Machinability based on machining orientation

## List of Tables

Table 4-1: Tool Parameters for the  $X_2$  design variable

Table 4-2: Test Parts Dimensions

Table 4-3: GA Results for 3 test parts showing Fitness and Design Variable values

Table 4-4: Results for CNC-RP with 3 test parts

## Abstract

This thesis presents a new method for Computer Aided Process Planning (CAPP) for a subtractive Rapid Prototyping (RP) process. The “CNC-RP” process uses a 4-axis CNC machining center to create parts with flat end-mills. The objective is to determine the optimal system parameters for the RP process - those that enable parts to be created in a shorter amount of time. Two main contributions make this possible. First, a method of generating different machining orientation sets enables the part to be created with the same level of safety and quality available with the current system. Second, machining time is related to tool selection. These two contributions are combined into a single objective function. A Genetic Algorithm technique is implemented to determine the best machining tool sizes and machining orientations. The results show that a Genetic Algorithm can be applied to a RP process plan to reduce the total processing time.



## 1 Introduction

### 1.1 Computer Aided Process Planning (CAPP)

Computer aided process planning (CAPP) is an increasingly important part of the interface between the design and manufacturing engineering processes. A CAPP system provides an important digital link between a CAD model and manufacturing instructions. The CAPP system is developed while the manufacturing method is being determined, and is used and revised throughout the life of the production system. CAPP includes the hardware systems involved in the process, the personnel operating these hardware systems, and data stored about current and past production. Some CAPP systems automate the manufacturing process by making real-time decisions based on the model of the part, sensors in the assembly hardware, or other sources. Together, the CAPP system's components will determine how to efficiently manufacture the product [Bose 1999].

Previously, this process planning was performed by a manufacturing engineer, based on engineering knowledge and work experience. Work began on CAPP systems in the mid 1970s when high volume manufacturing industries brought some of the first advances in the technology. Assembly manufacturing also used CAPP systems to improve part flow, reduce assembly errors, and increase the general efficiency of operations. The development of CAD and Computer Aided Manufacturing (CAM) systems brought CAPP into the machining industry. However a standard CAPP system for CAD/CAM applications has not emerged, mainly due to differences in CAD/CAM computer languages and specifically, the CAD 3D model format. NC programming has not changed much during this time, and most of the

work in CAPP for CAD/CAM has been in feature recognition, albeit with limited success [Cay and Chassapis 1997].

Early CAPP systems improved the manufacturing efficiency for new parts that had slight variations in their design from previous or similar current models. “Group Technology” theory utilizes the fact that parts with similar designs will have similar process plans. Therefore these simple “Variant” methods only consider the variations in the parts and then modify manufacturing instructions based on these variations [Chu, et al. 2000]. It is important to note that these CAPP systems are created based on previous manufacturing methods for the product, and worked from a fixed set of process plans. This CAPP system selects one detailed input instruction set, and outputs one simple, similar instruction set for the manufacturing hardware.

In contrast, “Generative” type CAPP systems create customized process plans for each new part based on the manufacturing hardware, product details, and other information sources. The generative process plan contains function variables that change for every part based on the CAPP system’s information sources [Cay and Chassapis 1997]. The system inserts values into its guiding functions to generate the process plan. This functional process plan incorporates the machine hardware and software. Variant CAPP systems also incorporate machine details, but only at the time that the CAPP system itself is created. This means that generative CAPP systems are able to adapt and reconfigure to changing manufacturing needs, making them more flexible.

One manufacturing area where CAPP has not been extensively researched is Rapid Prototyping (RP). Most RP technologies operate by depositing 2 ½ D “layers” of material derived from the cross-sections of the part. However, these systems have two strict criteria: 1) they must be able to make various arbitrary geometries using the same system hardware and 2) parts must be created with little input from the user before or during the process. These challenges, along with low production quantities (often not more than one part is created) have not made it economically feasible to develop specialized RP CAPP systems. One study even mentions that “layered manufacturing allows a direct and simple interface with CAD to CAM which almost completely eliminates the need for process planning” [Kochan, et al. 1999].

## **1.2 Motivation**

Some RP processes use completely subtractive manufacturing methods (Subtractive Rapid Prototyping, or SRP) for creating the part, rather than the traditional layer based additive methods. Unlike the exceedingly simplistic approach in the additive layer based process, an SRP system could significantly benefit from computer aided process planning. A process plan that can improve the speed of material removal without changing the quality of the final part can make SRP processes more viable in the RP market. The final part created by these SRP systems not only conveys the *form* of the design, but enables testing of the part's *function*. Some systems are even capable of making parts that meet the same quality requirements of a production part. This fact warrants the need for a more efficient system, since SRP could one day be an enabler of Mass Customization [Pine 1993] rather than

simply a rapid prototyping process. Companies will be able to evaluate designs faster and make it to market or redesign the part sooner since it will be easier and cheaper to test the functional performance and find any flaws early. For the fully subtractive and hybrid SRP systems currently on the market, CAPP would expand on their current capabilities. However, these benefits can only be realized if the previously mentioned “lights-out” requirement is met and the SRP systems do not lose any capability in creating a variety of geometries.

Unlike other RP systems that use CNC machining for only a part of the process, CNC-RP is a fully subtractive process that uses a 3-axis vertical milling machine with a 4<sup>th</sup> axis indexer [Frank, et al. 2004]. In CNC-RP a layer based, pocketing toolpath routine machines all of the stock material surrounding the part geometry, but leaves a structure of “sacrificial supports” used to fixture the part (keeping the part attached to remainder of the stock). This machining process is repeated for several orientations, or setups, by sequentially machining and then rotating the stock material around the axis of rotation (4<sup>th</sup> axis on the milling machine). A “Visibility” (VISI) program has been developed which returns the minimum set of machining orientations to completely machine every feature on the part. The current process is broken into two major steps designated as rough and finish machining.

The most significant cost in CNC-RP is machining time, which highlights the need for a well developed CAPP system. A reduction in processing time will make CNC-RP a more viable RP technology. The two main components of a CAPP for CNC-RP are 1) selecting machining orientations, and 2) selecting tool sizes. Machining tool accessibility refers to the

ability of a machining tool to access a geometric feature from a particular orientation. In CNC-RP, the 4<sup>th</sup> axis indexer enables access to many features by using all required setup orientations about the axis of rotation. However no analysis is done to optimize the sequence of machining orientations based on the part geometry. In other words, the current machinability analysis only requires that all features are created after all setups are complete, but it does not necessarily do so in an efficient manner for every part.

To perform analysis on the part geometry, the machining orientation and machining tool size need to be known. However, the roughing tool size is currently based on an empirically developed linear relationship to stock diameter; the larger the stock diameter – the larger the required tool. The finishing tool is chosen by selecting the tool in the carousel with the smallest diameter in a length greater than or equal to the diameter of the stock. Furthermore, there is no relationship between the size of the roughing tool and the size of the finishing tool. It should be apparent that the current CNC-RP process has an arbitrary method of choosing tool diameters, and satisfies only minimum criteria for selecting machining orientations.

### **1.3 Objective**

The primary objective of this thesis is to develop a Computer Aided Process Planning system for a subtractive rapid prototyping process, namely the CNC-RP process. The first sub-objective is to create a process planning algorithm that will determine a set of machining orientations and machining tool sizes that minimize the total machining time. The process

planning algorithm will need to integrate three major concepts necessary for CNC-RP to be both effective and efficient in creating parts, but also satisfy the overarching goals of an RP system; to be completely automated, and run in a “lights-out” manner with no human intervention.

First, the process planning algorithm will integrate existing visibility algorithms that have been previously used to establish necessary angles for machining. The process planning algorithm will also enforce a heuristic approach to machining orientations that was intended to avoid thin webs of stock material that can cause catastrophic failure during the machining process. Then the algorithm will analyze the geometry of the part to determine accessible volumes of material for each orientation, for both roughing and finishing tools, and relate these accessible volumes to total machining time.

The second sub-objective is to develop a mathematical model representing the setups, tools and machining parameters such that an objective function for a Genetic Algorithm process can be established. This Genetic Algorithm process is intended to introduce new candidate machining orientations, beyond the naïve approach of the previous visibility algorithm. It will populate multiple solutions and then evaluate them based on a minimum machining time criteria.

This thesis will present a new approach to process planning for subtractive prototyping and will lay the groundwork for future efforts in optimizing such a process. It is the first significant effort at not only making CNC-RP feasible and safe, but also make it a viable RP

technology with comparable processing times. A major contribution of the work is the integration of numerous concepts, some developed for CNC-RP, and others developed for traditional machining process planning, along with innovative concepts that have only recently emerged from advanced rapid prototyping technologies. The remainder of this thesis will be presented as follows: Chapter Two will present an overview of existing work in Rapid Prototyping, Machining and Computer Aided Process Planning. Chapter Three will provide a general overview of the solution methodology. Next, Chapter Four will present the technical details and development of the process planning algorithm while Chapter Five will present the Genetic Algorithm approach and implementation of the thesis, along with results. Lastly Chapter five will present conclusions and recommendations for future research.

## 2 Literature Review

### 2.1 CNC-RP Overview

One method of determining tool accessibility and required size is to implement a very simple CAPP that will meet all the requirements of an SRP process. CNC-RP is a method that uses a simple and robust method to create fully dense metal parts [Frank, et al. 2004]. The system uses a 3 axis vertical machining center with a 4<sup>th</sup> axis indexer that holds round stock material in its chuck jaws. A sacrificial support system is the fixturing method used during machining [Boonsuk 2005]. A two stage roughing and finishing strategy is used where every machining setup uses simple pocket machining toolpaths to remove material in a layer-based fashion. The indexer is used to rotate the part to the next machining setup. The angular positions necessary to machine the part are determined with a visibility (VISI) algorithm that analyzes cross sectional slice data derived from a polygonal CAD model (STL file). The VISI algorithm maps the visibility of each polygonal segment on every slice of the model. This results in the formulation of a Minimum Set Cover problem, where a minimum set of indexer angular positions is needed in order to access every surface on the part [Frank, et al. 2006].

The CNC-RP system is a very robust and safe system that is capable of creating functional parts. The hardware required for CNC-RP is not proprietary to the system since any 3-axis CNC machine with a 4<sup>th</sup> axis indexer could be used as a CNC-RP machine. This enables the system to create RP parts with high precision, at a relatively low cost. The fixed costs are determined by the system hardware, while the variable costs include stock material and machining time. The machining time can be considerably long for complex geometries



because of the simple layer-based toolpath planning and much of the stock material is waste since CNC-RP uses standard round stock for all part geometries.

## **2.2 Hybrid RP Systems for Metals**

Some hybrid methods reduce the amount of material waste and machining time, by creating an oversized part using an additive method. Some examples of this include Laser Engineered Net Shaping (LENS), Direct Laser Deposition (DLD) Selective Laser Sintering (SLS), and Direct Metal Laser Sintering (DMLS) [Liou, et al. 2007]. These Hybrid RP systems can provide good accuracy with their use of CNC machining, and depending on their additive method can provide full density. Hybrid RP systems are especially useful when material waste must be kept to a minimum, for example, when expensive materials are used or when constructing large-scale structures. One disadvantage is that Hybrid RP system must use high quality metal powders, proprietary equipment, and energy consuming high power lasers. Equipment costs make it difficult to implement these systems in small and medium sized companies.

While Hybrid RP systems have found a niche in certain industries, widespread use as Rapid Manufacturing (RM) tools is limited not only by the costs mentioned above, but also by the constraints imposed by their methods. To create fully dense parts, high power lasers are required to melt the metal powders. Sintering (SLS, DMLS), and powder feed (DLD, LENS), must be tightly controlled to ensure an accurate size and shape of the pre-machined (oversized) part [Liou, et al. 2007]. There is a tradeoff between the accuracy of the additive

method, and the speed and method of machining. The increasing accuracy of the additive method does not relate to an equivalent savings in the machining process. The additive processes cannot and do not create net-shape parts; hence machining processes are required. Therefore unique toolpath planning must be done for each pre-machined part. At some point the improvements in the accuracy of the additive method create no savings in machining time. For a given final part accuracy there is a limit that will be reached for improvements in total manufacturing time.

### **2.3 Hybrid Methods**

Though hybrid RP systems have some limitations as discussed above, researchers have developed feature recognition, feature decomposition, automated process planning, and tool accessible area relationship graphs to attempt to reduce these limitations. D'Souza develops a machining cost function based on a pre-determined set of data for a feasible set of tools for a 2½-D part [D'Souza 2006]. Using tool costs, machining costs, accessible volume, and air cutting time, the optimal set of 2½-D shapes are generated. Four methods of evaluating optimal tool sequencing that adheres to these constraints are considered. This method is unique in that it uses actual toolpath lengths to calculate machining time, and uses tool data to establish toolpath planning. Each tool's machining area defines machining regions which are then sequenced. The complexity of the problem is reduced by recognizing that: "a larger tool is a strict subset of the accessible area of a smaller tool" [D'Souza 2006].

Pinilla develops a set of graphing techniques for feature recognition [Pinilla, et al. 1998]. An automation and Process Planning algorithm was developed for the process called Shape Deposition Manufacturing (SDM). The system identifies “Single-Step” geometries (those geometries that are created in one step in the SDM process). These decomposed geometries are then compiled into an “Adjacency” graph (based on Single-Step geometry adjacency). From this graph, a “Precedence” graph is built to sequence the SDM process, with the optimal graph being the one with the shortest machining time. A downfall of the system is inherent in the SDM process: “The more steps, the more the building time is consumed in the conditioning procedures” [Pinilla, et al. 1998]. Even if this method could be applied to DMLS, the number of process steps will be a difficult constraint to overcome.

Liou et al provides a new process planning approach using DLD [Liou, et al. 2007]. 3D polyhedron skeleton analysis is used to create “sub-parts”. These sub-parts are created one at a time, each being built up and then machined before the next sub-part is added. This system avoids support structures by turning to different orientations based on each sub-part geometry. Sub-part creation is sequenced by using two main constraints. One is that the 2<sup>nd</sup> sub-part be built on top of the 1<sup>st</sup>, and the 3<sup>rd</sup> on the 2<sup>nd</sup>. The second is based on tool accessibility which limits the types of geometries that can be created. Together these processes make up the Laser Aided Manufacturing Process (LAMP).

Hur attempts to improve upon the SDM process using a 5-axis CNC machine to create layers based on part geometry at undercuts [Hur, et al. 2002]. The system does not use STL files, instead it uses STEP geometry. In this process, “thick” layers of part material are added on

top of previously created geometry. This eliminates the use of elaborate additive processes, by only requiring equally sized layers, and adhesive to bond these layers together. However, the complexity of five-axis machining requires well developed algorithms. For each layer, the part geometry is divided into pieces called “deposition feature segments” (DFS). Each DFS is machined from each of the four edges of the layer, and then any features perpendicular to the tool are machined. Finally any unique or special features called “machining feature segments” (MFS) are identified and machined in the final step. This process has potential to be a very fast RP technology; however, the shear strength between layers is a concern if it to be used as a rapid manufacturing system that creates functional parts.

## **2.4 Accessibility Analysis**

As in the processes discussed thus far, any subtractive prototyping process needs to rotate its fixture to a particular number of setup orientations. In the LAMP process a “machinability check” is performed [Liou, et al. 2007]. As more sub-parts are created, there is an increasing potential for a tool collision. In the system described by Hur, little is mentioned of collision detection. A five-axis machining center creates many degrees of freedom which make collision avoidance difficult. In the LAMP process the 3D polyhedron skeleton model determines build orientations. Since it only relies on the skeleton algorithm to correctly identify overhanging features and other inaccessible features, the system may miss opportunities to machine more features. Another check for tool accessibility could improve

this system's capabilities by rotating the part to an orientation that can access a particular feature.

Tool accessibility is analyzed on sculptured surface more directly by Lee (et al. 1992). The surfaces considered, highlight the need for tool accessibility and machinability analysis. B-spline surfaces are broken down into polygon approximations by finding the intersection of "cutting planes" and the part. With these polygons the islands and pockets of the part can be identified. Lee goes further to create a classification scheme to identify polygon segments as islands or pocket boundaries, improving collision detection further. Using all cutting plane polygons, the volume of a pocket can be determined. Based on the choice of tool this volume can be removed at different speeds.

Lim (et al. 2001) and Balasubramaniam (et al. 2001) determine machinable volume with similar analysis techniques using "slice" files created from STL files. Lim refers to the calculation as Tool Access Volume (TAV). For a given tool, the slice file polygons can be offset so that the machinable area for a given slice can be determined. Then the machinable volume for a given step-down is determined by taking the union of the slices in the step-down and multiplying by the amount of the tool step-down. Finally, the volumes for each step down are added up, to give the machinable volume for each orientation. Figures 1 and 2 from [Lin and Gian 1999] provide a good illustration of the volume being removed and the volume calculated using the TAV method.

This information can be very useful; however, the previous research has not addressed which orientations the part needs to be machined from. Frank develops a “Visibility” algorithm to identify these orientations [Frank 2003]. With STL slice files, the minimum necessary machining orientations for a given part geometry are determined. This information, combined with the volume of material to be removed can be very useful in determining machining time for a subtractive Rapid Prototyping process.

## ***2.5 Tool and Machining Orientation Sequencing***

Lin’s calculation is similar to the TAV method; however, the goal of his research was to machine thick layers using multiple tools. Lin’s method analyzes each layer (material between STL slices) and using multiple tools with decreasing diameter, machines each layer. Each layer thickness is determined by the largest tool’s cut depth. For one layer the tool uses three different toolpath types. The first is a “linear pocketing” routine moving the tool linearly across the layer, machining all the accessible volume. The second contouring toolpath removes the material by following the pocket boundary and island contours. The last toolpath removes the steps created by paths one and two by machining around the contours from the bottom of the layer to the top of the layer. The next tool machines the material left by the first tool using the same three toolpath types. However, the smaller tool’s cut depth is smaller than the previous tool, therefore, it must repeat the 3 toolpaths until the bottom of the layer is reached. The method is unique, but has redundant machining and the sizes of tools are not discussed well. One could argue that the algorithm can be applied to

any set of tools; however, there is likely an optimum set of tools to use with this technique [Lin and Gian 1999].

Lee introduces a method to determine an optimal set of tools for any arbitrary geometry. First, tools are chosen by a simple classification scheme illustrated in [Lee, et al. 1992]. This scheme decides whether roughing and finishing size tools are to be used, and whether the tool is a ball or flat end mill. A relationship is developed to relate the areas of two adjacent layers, their depths, and the radii of the cutting tools. Based on this relationship, the two layers are treated separately or merged into one layer using the smaller of the two tools analyzed. This is continued until the bottom of the feature is reached. This method met the requirement to avoid gouging while still finding the minimum Material Removal Rate (MRR). However, unlike Lin's approach, these authors do not use a sequence of tools, beginning with the largest tool. Yet they identify an important relationship between safety, by checking for gouging and minimum material removal rate (MRR)

Quinsat and Sabourin (2003) acknowledge the use of MRR to reduce total machining time, but claim that "no methodology is presented to choose a machining direction for the whole surface". "Directional Beams" are introduced, which are the orientations by which a point on the surface can be machined. A fitness function is given for the independent variables: surface points, and tool parameters. The intersection of all points (and their Directional Beams) will return the possible set of machining orientations. If this set exists, an algorithm iterates to find the highest machining rate at each point on the surface. With the tool parameters as one of the independent parameters, the tool selection is automated with the use

of this algorithm. Case studies showed good correlation between testing and algorithm results. The only drawback is that this method is restricted to surface/contouring machining.

To find an optimal tool set for a volume removing operation, Balasubramaniam uses a network flow problem heuristic method. The network model generates an optimal tool sequence if it is “accessible by a tool at all slices increases monotonically down” the discrete, ordered set of tools. This optimal solution is found using Dijkstra’s algorithm [Leiserson et al. 1995]. Lim (et al. 2001) defines a measure of a tool’s effectiveness to remove a volume of material called Relative Delta-Volume Clearance Rate (RDVC) (min). This measure assumes that a “finishing” tool is able to machine all of the material in a certain pocket feature. From testing a logical note is made: “as tool diameter increases beyond the most effective” roughing tool, “the RDVC rate also increases”. In other words, the more residual material is left by the roughing tool, the longer it will take for the finishing tool to machine that material (assuming a fixed finishing tool MRR).

Some work has introduced methods for improving the process plans and efficiency of RP systems; however the research intent was often not based purely on reducing the production time. Research has improved the ability of machining tools to access geometric features. Other research has considered the most appropriate orientation in which to build the part. The process plans resulting from these methods have been developed because the part could not be manufactured with current RP technologies, or could only be made with structurally weaker materials. Few of these technologies have attempted to improve the speed of



manufacture using CAPP methods. With the intent of RP systems in mind (low production or single part creation) it makes sense that little research has addressed this area.

## **2.6 Summary**

If more a more robust CAPP can be added to CNC-RP there are many opportunities for improvement. There is a lack of robust choices in tool size and machining orientation sequence. A simple linear relationship to stock diameter determines roughing tool diameters. Finishing tool size is not related to roughing tool size or part geometry. Only the VISI results and a simple 3 angle heuristic method of roughing are being used to determine machining orientations. Lim's TAV calculation is only performed on a 2.5D part and with one small finishing tool. No other orientations are analyzed. Lin and Balasubramaniam use a 3D version of the TAV calculation. However Lim clearly defines the Relative Volume Delta Clearance (RDVC) which determines the effect of combining two tools to machine a part [Lim et al. 2001]. Once a relationship between two tools is found, this relationship can be extended to more tools. Unfortunately these examples only analyzed a particular orientation. What if there are more orientations on the part geometry to machine? It seems reasonable to extend this method for use in a system like CNC-RP with the 4<sup>th</sup> axis indexer rotating to these different orientations. The VISI algorithm [Frank, et al. 2004] is capable of finding these orientations. Quinsat approached a multi-orientation like this in a similar way; however, it was not intended for pocket machining purposes. This thesis will address the limitations of the previous work, while including some methods in a new, integrated

approach to computer aided process planning for subtractive rapid prototyping. The following chapter provides an overview of the general solution approach.

### 3 Overview of Solution Methodology

Previous work has shown that rapid machining can be employed as a viable rapid prototyping process; however, there is much room to improve and optimize the process planning methods. This thesis provides a method for satisfying multiple criteria necessary to make rapid machining not only functional, but more cost effective. The research involves two major areas; computer aided process planning and Genetic Algorithm. This chapter provides an introduction to the problem and then presents an overview of the solution approach.

#### 3.1 Background

Subtractive Rapid Prototyping (SRP) is a process that machines a complex 3D model using only CNC machining. SRP is present in different forms in various RP processes. This research focuses on CNC-RP which uses a 3-axis CNC machining center and a 4<sup>th</sup> axis indexer. The indexer is used to rotate the part to different orientations. For each orientation, the process machines all visible surfaces in a layer-based fashion. The motivation is to avoid complex feature-based methods by simply requiring that ALL surfaces of the part are machined after ALL machining orientations are complete. As such, the part *emerges* from stock material throughout the process.

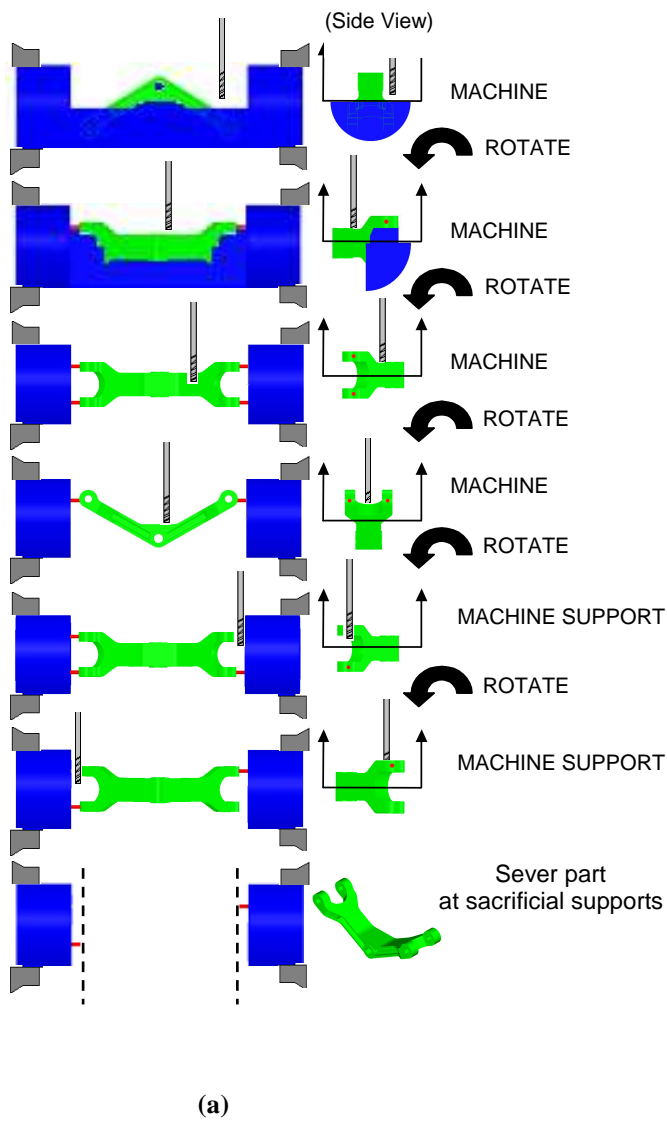

**Figure 3-1: Subtractive Rapid Prototyping, (a) Steps of the Process [Frank, et al. 2006]  
(b) Finished part created with SRP**

This process involves both roughing and finishing steps that have several requirements, some of which are unique to rapid machining. First, the roughing toolpaths are intended to remove as much excess stock as possible from a variety of orientations. As with either roughing or finishing toolpaths, the steps of the process must complete without failure, must machine to

some required depth, and must occur automatically. There is no human process planner, so this must all be done using computer algorithms. Figure 3.2 illustrates an end view of a part (viewing along the axis of rotation), showing several machining orientations ( $\theta_{1 \rightarrow 3}$ ) and the machining depths for the first orientation (“ $Z_1$  min” and “ $Z_1$  max”).

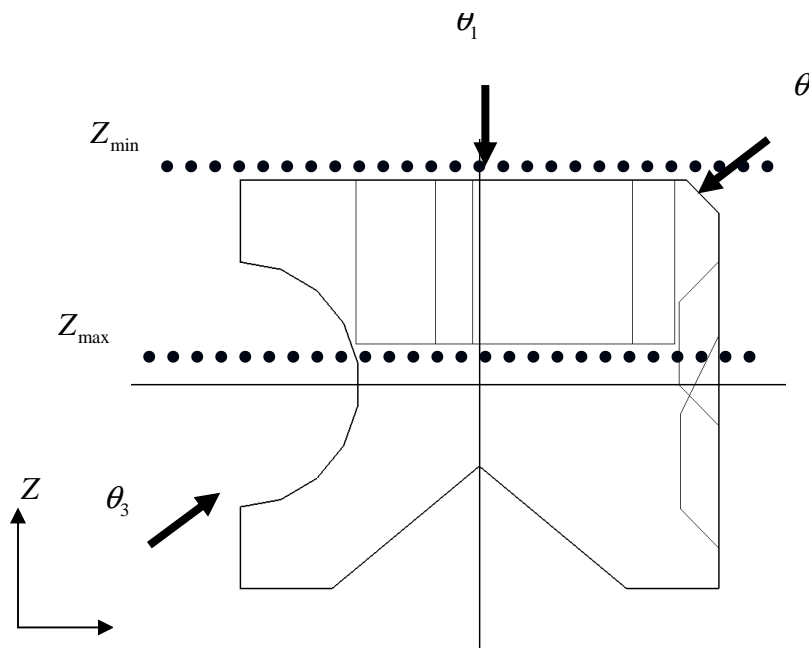

**Figure 3-2: Current machining orientations, max and min depths shown for first orientation**

The current process planning method for rapid machining is overly simple in order to avoid failure: machine each orientation from the edge of the stock material to the furthest visible surfaces. In addition, the orientations are chosen such that they only need to satisfy one criteria: everything on the part is created after machining from all orientations. The lack of additional process criteria leads to several inefficiencies. For some part geometries, there may be multiple sets of machining orientations, and each of these sets could potentially be smaller or larger than the next. It is highly unlikely that each orientation set can be machined in the same amount of time. Furthermore, for each of these orientation sets, there are a wide

variety of tool choices that could be made, which could have a significant affect on the process efficiency.

This thesis attempts to improve the process planning for subtractive RP with two major advancements. One, it proposes a more advanced algorithm for process planning, taking into account how much is machinable for different sets of orientations, what tools are used, and avoiding thin webs. This solution is a systematic approach to satisfying multiple criteria, within the existing requirements of the rapid machining process, that is, it must be a completely automated, lights-out process that requires little or not human intervention. Next, this thesis formalizes a solution by using a Genetic Algorithm method to find a suitable set of machining orientations and tool sizes. The remainder of the chapter presents the two major areas of research, and highlights basic components of each proposed approach.

### ***3.2 An improved process planning algorithm***

An improved process planning algorithm for CNC-RP will reduce the time and cost of safely creating a part. The proposed method will attempt to integrate the existing functions and criteria for CNC-RP which specifies that the part must be completely created, the process cannot fail, and the process must be automatic. These criteria must be met while adding more effective decision making algorithms that take into account machining time. The proposed method will involve 1) adapting the Visibility (VISI) program to meet the Thin Web Avoidance constraint and 2) calculations to determine accessible volumes of material

for each orientation, for both roughing and finishing tools. Each component will be summarized below, and then a full development will be provided in Chapter 4.

### 3.2.1 Adapting Visibility for Thin Web Avoidance

One of the most significant constraints in the CNC-RP process is the removal of material during the first machining steps. The first machining steps must remove the bulk of the stock material, which obviously can be accomplished with a variety of approaches. The first and most logical would be to machine from a set of two orientations that are  $180^\circ$  apart. However, if this choice is made, a “thin web” is generated during the second of the two orientations that are  $180^\circ$  apart. When pocket machining from the stock radius to the center of the stock material, the last layer being machined becomes a thin web of material. When machining the thin web, the tool is likely to break by wrapping the thin layer of metal around the tool.

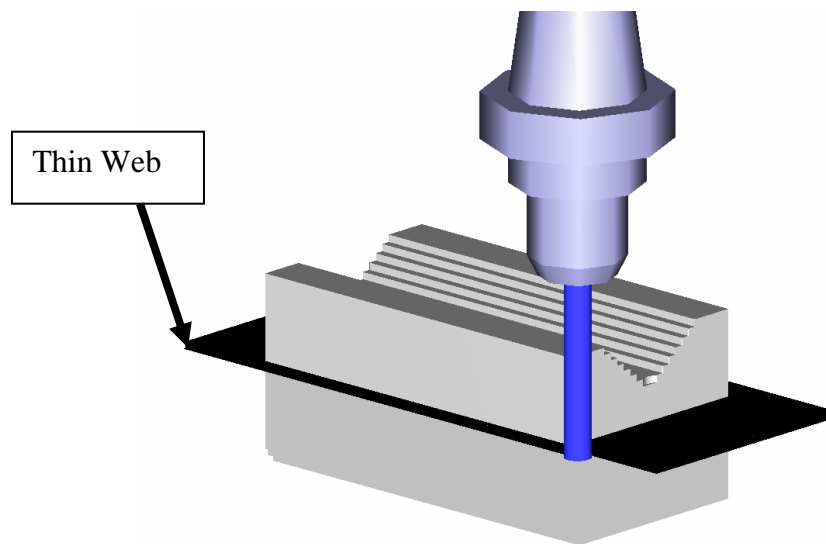

Figure 3-3: Machining simulation at  $180^\circ$  after  $0^\circ$  was machined

The current heuristic method to avoid creating a thin web is to machine from  $0^\circ$ ,  $135^\circ$ , and  $225^\circ$  which is used to safely remove the bulk of the stock material. The Thin Web Avoidance constraint has been implemented in the current CNC-RP process and has proven to be a safe and reliable way to begin machining the part out of the round stock material. For a CAPP, this criteria is helpful in establishing limits within which other improvements can be made.

Without any user interaction, the Visibility program (VISI) used in CNC-RP outputs the minimum set of indexer angles that are necessary to completely machine the part. This is the minimum set of machining orientations. During the process at least these orientations must be used in order to completely machine the part.

The three arrows in Figure 3-4 (a) show the VISI result without any user input. The dotted lines signify the min and max visible depths for the  $\theta_o$  orientation. Notice that there are only three machining orientations output by VISI for this particular geometry. These three orientations are the only three necessary to completely machine this part.



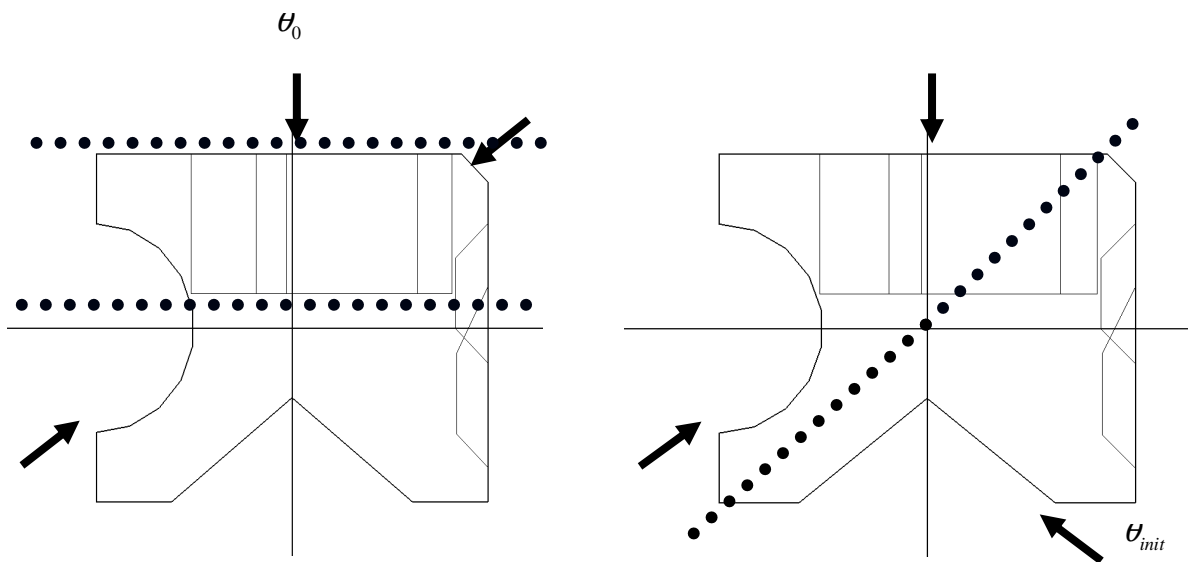

Figure 3-4: (a) Minimum set of orientations (b) Set of VISI results given an initial angle

The three arrows in Figure 3-4(b) designate a VISI solution given an initial orientation of  $\theta_{init}$ . Given a user input “initial” angle, VISI will determine which surfaces can be machined from that orientation (the surfaces between the dotted lines of Figure 3-4(b)). The other orientations that are needed to fully machine the part are then calculated. By providing an initial angle to VISI, a different set of machining orientations can be generated. With this feature of the VISI program, an improved process planning algorithm can analyze different sets of machining orientations, and determine which set can be machined in the shortest amount of time.

### 3.2.2 Tool Accessibility, Selection and Machining Time calculations

#### Tool Access Volume (TAV)

The TAV method was originally developed to determine tool selection and tool sequencing [Lim et. al., 2000]. The TAV method can be generalized to multiple aspects of CNC-RP. Since CNC-RP uses a 3-axis machining center with a 4<sup>th</sup> axis indexer, the TAV method can be modified to represent an accessible volume for a given orientation of the machine's indexer. In addition, the method can be extended to CNC-RP by treating the cylindrical stock material as pocket geometry. Since the stock material must be removed in a similar manner to pocket machining (layer-by-layer) the TAV method can be applied. Finally, the method uses 2 ½ D geometry to analyze what was referred to as "Residual Volume". The larger the machining tool that was used, the larger the Residual Volume it left behind for subsequent tools to finish machining. This concept allowed the authors to establish a connection between the geometry of the part and an optimal set of tool choices and tool sequencing. Again, this is useful for an improved process plan for CNC-RP because the Residual Volume is directly related to tool size and machining orientation.

#### Relative Delta Volume Clearance

Once the machinable volume is determined, the time required to machine that volume must be calculated. The time can be determined by dividing the machinable volume by the tool's Material Removal Rate (MRR). This thesis uses the Relative Delta Volume Clearance (RDVC) calculation by Lim (et. al 2001). This calculation establishes the relationship between two tools' machinable volumes; which can be determined by the aforementioned

TAV method. For the CNC-RP process, two tools are used, a roughing and finishing tool. The RDVC calculation will determine how much time it takes the roughing tool to machine the total volume that it can access, and add to that the time it takes the finishing tool to machine the Residual Volume left by the roughing tool. Therefore the volume of material removed by the roughing tool affects how much material is left for the finishing tool to remove.

For the CNC-RP process, the tools are chosen based on linear relationships to stock size, and on whether they are long enough to reach the maximum depth specified by the visibility program. The absence of tool selection criteria directly affects the total machining time. Each tool in the carousel will have an optimum cutting speed at which it can perform; therefore, the tool with the fastest cutting speed available for a particular geometry should result in the shortest total machining time. The goal of these additional decision rules will be to include the effects of tool size and speed on the total machining time.

### **3.3 Genetic Algorithm Methodology**

Vanderplaats (2001) defines *design optimization* to be “the actual process of defining the system”. In section 3.2, methods were described that help define the design objective and design variables, however, the method of defining the system requires design Genetic Algorithm. This is necessary because a unique process plan must be generated for every part created with the CNC-RP process. New process plans must be generated because the CNC-RP process often manufactures a part geometry only once. Therefore, applying design

optimization to the manufacture of a part in CNC-RP will define the system by determining the values to use with the improved process plan.

One of the design variables discussed was the “initial angle”  $\theta_{init}$ , that when provided to the visibility program (VISI), outputs a complete set of machining orientations totaling up to “ $n$ ” orientations including  $\theta_{init}$ .

$$\theta_{init} \Rightarrow VISI \Rightarrow \{\theta_{init}, \theta_1, \dots, \theta_n\} \quad (3.1)$$

The second design variable is the tool diameter. The Tool Access Volume (TAV) method, can determine the amount of volume removed for a set of roughing and finishing tools.

The Relative Delta Volume Clearance (RDVC) calculation can then be used to determine how long it takes to machine the part at an orientation. The TAV value for the roughing tool ( $V_R$ ) and finishing tool ( $V_F$ ) are each divided by their Material Removal Rates (MRR) resulting in a value for the total machining time.

$$RDVC = \frac{V_F}{MRR_F} + \frac{V_R}{MRR_R} \quad (3.2)$$

The solution approach will use both the RDVC calculation and the VISI program to find the optimum set of machining orientations and tool diameters. This optimum solution is the set

of machining orientations and tool diameters that can machine the part geometry in the shortest amount of time.

### **3.4 Summary**

This chapter presented an overview of the thesis motivation and a general description of the solution methodology. It was suggested that the proposed new methods will improve process planning by adding additional criteria that will make the rapid machining process more cost effective by reducing machining time. Then, it was suggested that a Genetic Algorithm problem could be solved to determine the best machining orientations and tool sizes. The following chapters present these two major contributions in more detail and then results from an implementation are presented.

## 4 Solution Approach

This chapter presents methods for improving the performance of a subtractive rapid prototyping process through new process planning algorithms and approaches to optimizing setups to reduce machining time. This includes an improved process planning methodology, which can take into the account the constraints and limitations of the current RP approach, but also provide better analysis of the parameters involved in each setup. New metrics are proposed that will evaluate process plans and provide more effective solutions. These new measures can then be used as input to a Genetic Algorithm approach that will search for the best setup and process plans for an arbitrary part.

### ***4.1 An improved process planning algorithm***

An improved process planning algorithm will take full advantage of the many capabilities of the current CNC-RP process. In the first section of the solution approach, the current Visibility (VISI) analysis is discussed and a method to enforce the Thin Web constraint is proposed. Next, calculations for determining tool accessibility and machining time are performed for each set of machining orientations to establish criterion for roughing tool selection.

### 4.1.1 Adapting Visibility Analysis for Thin Web Avoidance

#### Current Visibility (VISI) Analysis

Visibility analysis is performed in order to determine the necessary finish machining orientation set that will machine everything that is visible about an Axis of Rotation. The following example part demonstrates how the VISI program determines which machining orientations are necessary in order to completely machine the part.

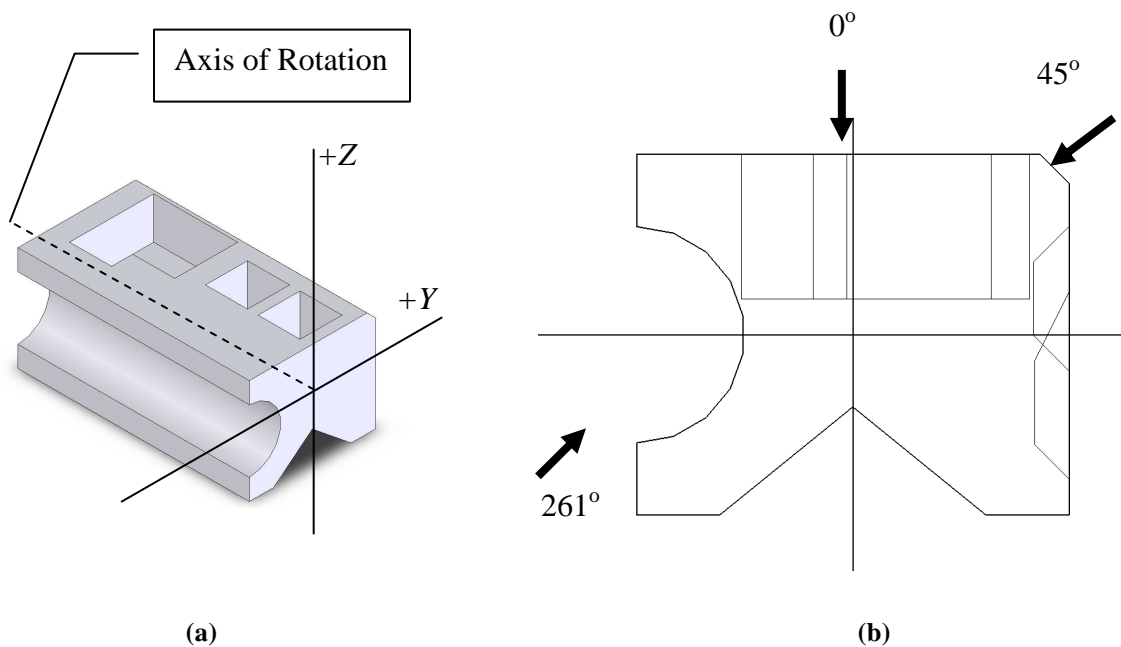

**Figure 4-1: Sample part illustrating visibility analysis (a) Isometric view of example part with axis of rotation (b) Right side view showing Finishing Angles output by VISI**

For the example part shown in Figure 4-1, the current Visibility program determines that there are three machining orientations. The first and second orientations at  $0^\circ$  and  $45^\circ$  (machining the blind features shown in Figure 4-1), and the third orientation at  $261^\circ$

(machining the notch on the bottom of the part and the semi-circle on the left side of the part).

The primary objective of the VISI algorithm is to determine what orientations are required in order to completely machine the part surfaces [Frank, et al. 2006]. Due to this objective, the CNC-RP Process is able to ensure that everything on the part has been created. This concern is foremost in a system that does not rely on human input for determining how the part will be created. Due to this objective, the VISI analysis is very useful in determining where the part must be machined from during the last stages of creating the part – the finish machining steps. However, as the part begins to be created, the rough machining of the part may benefit from a different set of machining orientations that do not coincide with the orientations output by VISI.

#### *The problem with Thin Webs*

A critical constraint in rough machining is that the creation of thin webs of material must be avoided. During the first few machining steps, the bulk of the stock material (the piece of round stock that the part is being created from) has not yet been machined. The first and most logical choice of machining orientations would be to machine from two sides of the part geometry ( $0^\circ$  and  $180^\circ$ ) and from each orientation, machine the stock material down to the axis of rotation. Machining from just one side of the part could leave a significant amount of material on the opposite side of the part. However, machining from  $180^\circ$  from a previous operation is where the Thin Web problem arises (see Figure 4-2).



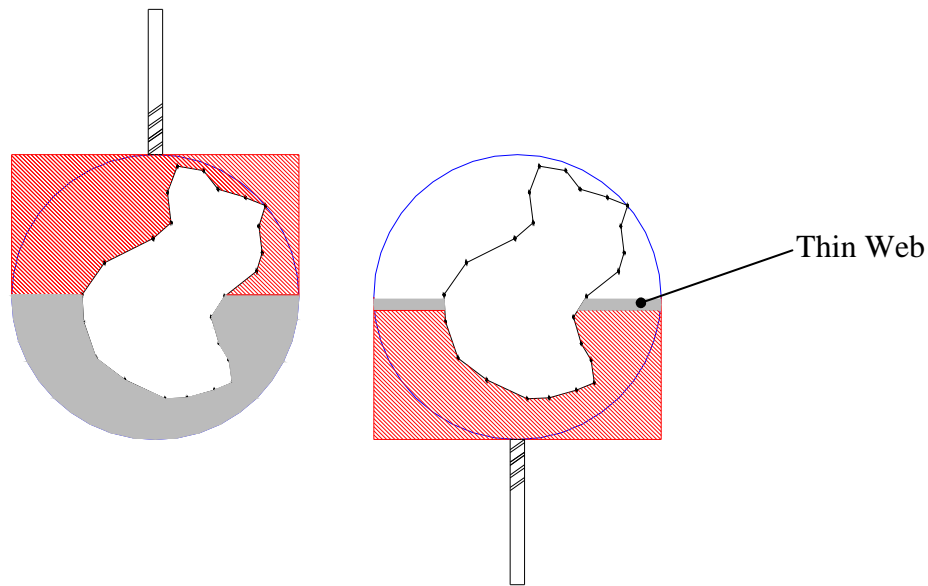

**Figure 4-2: Machining operations generating a Thin Web [Frank, 2003]**

After the first orientation is machined, the second orientation is machined from the opposite side of the part. As the tip of the end mill approaches the center of the stock, a *thin web* of material begins to appear that is as wide as the stock diameter. As the end mill machines this last layer of material, the layer is thin enough, that the machining tool does not produce metal chips. When machining the thin web, the tool is likely to break by wrapping the thin layer of metal around the tool. Therefore, machining the thin web needs to be avoided so that the CNC-RP process can safely perform rough machining.

#### Current Thin Web Avoidance Methods

To avoid thin webs during the removal of the bulk of the stock material, three roughing angles are currently employed. Previous research has shown that using a three roughing angle approach is an effective heuristic method [Frank 2003]. It is assumed that rough machining

must be completed for each finishing orientation so that the finishing operations only need to machine away the material that the roughing tool could not machine. If the finishing angles output by VISI do not include a set of three angles that meet the thin web constraint, then roughing orientations must be added until the constraint is satisfied.

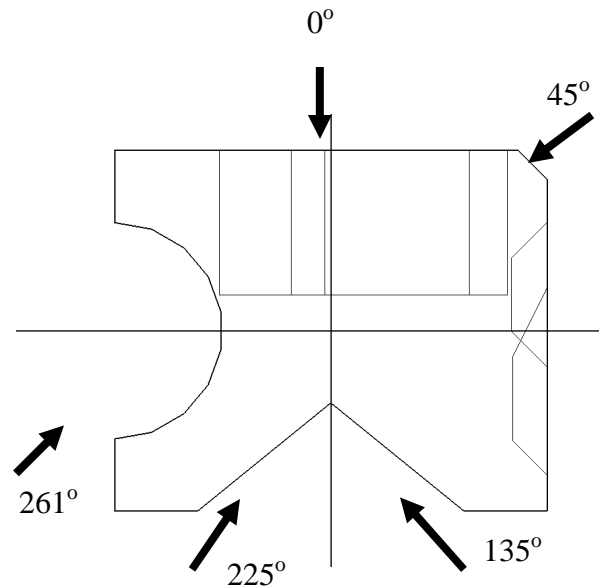

**Figure 4-3: Example part illustrating extra angles to avoid thin webs**

As an example, Figure 4-3 shows a part with a set of angles from VISI that included  $0^\circ$ ,  $45^\circ$ , and  $261^\circ$ . These angles do not satisfy the thin web constraint; therefore it is necessary to add two more roughing orientations, in this case, at  $135^\circ$  and  $225^\circ$ . For this example part, the machining orientation at  $261^\circ$  will be able to machine the surfaces machined by the  $135^\circ$  and  $225^\circ$ . Therefore, the current method to avoid thin webs would include redundant machining because the  $261^\circ$  orientation would machine the notch on the bottom part again, after the  $225^\circ$  and  $135^\circ$  orientations. Furthermore, some of the surfaces machined by the  $45^\circ$  orientation would be machinable by the  $135^\circ$  orientation.

In the improved method of this Thesis, the original heuristic method of using  $0^\circ$ ,  $135^\circ$ , and  $225^\circ$  was adjusted to allow two of the three angles to be  $120^\circ$  to  $150^\circ$  apart from the third angle. For example, in Figure 4-4 the gray shaded regions illustrate ranges of orientations about  $135^\circ$  and  $225^\circ$ . Given a theta value of  $0^\circ$ , any two angles that individually fall within the shaded regions would meet the Thin Web Avoidance criteria.

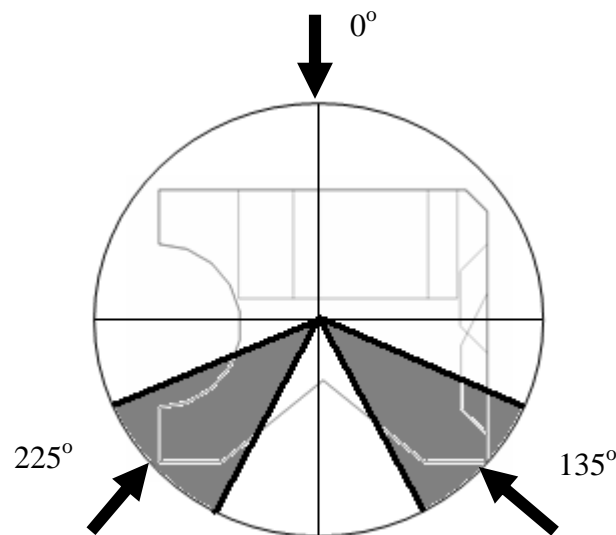

**Figure 4-4: Illustration of adjusted thin web avoidance method**

Next, the finishing machining orientation set is examined to determine if there are three angles that satisfy the adjusted three angle heuristic. If three angles are found that satisfy the constraint, these angles are used for the first three rough machining operations. This addition to the three angles heuristic has been tested and implemented in the current CNC-RP system. Using this improved approach, the search for roughing orientations within finishing orientations often results in a smaller set of machining orientations. Of course, the likelihood

of finding three roughing orientations in the finishing orientations set is highly dependent on the geometry of the part.

### *A New Method to Avoid Thin Webs*

Since the thin web constraint must be satisfied and the current VISI analysis outputs only one set of machining orientations, a new method is developed to avoid thin webs. In this new approach, the VISI program is given an input parameter that will be called the “initial angle”. The intent of this new approach is to generate more machining orientation sets that obey the Thin Web Avoidance constraint and completely machine the part.

In the previous example shown in Figure 4-4, the VISI results that three machining angles should be used at  $0^\circ$ ,  $45^\circ$ , and  $261^\circ$ ; however, if an initial angle at  $270^\circ$  is provided to VISI for the same part (Figure 4-4), the following orientation set results:  $\{0^\circ, 130^\circ, 270^\circ\}$ . Figure 4-5 illustrates the three setup orientations found by providing an initial angle of  $270^\circ$ .

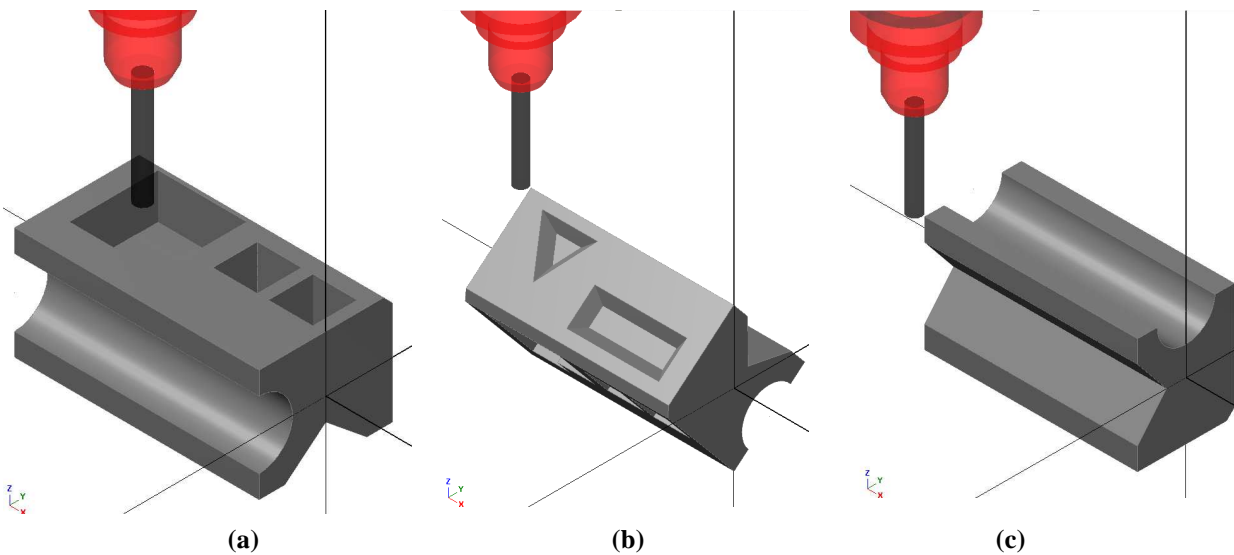

**Figure 4-5: Example part at three machining orientations (a)  $0^\circ$ , (b)  $130^\circ$ , and (c)  $270^\circ$**

The original solution is derived from a greedy algorithm inside the visibility program. As such, the greedy approach is to select the first angle for setups as the angle that can machine or “covers” the most surfaces on the part. Each subsequent angle is the next angle that satisfies the most surfaces, assuming each covered surface is removed from the search sequentially. The hypothesis of this thesis is that forcing a more exhaustive search through initial angle may result in a better set of angles, and preferably, one that also satisfies the thin web constraint. With the example above, this new approach reduce the rough machining orientation set from four machining orientations down to three. In this example, previous knowledge about the part was needed to determine what initial angle to provide to VISI (it was known that  $270^{\circ}$  was a finishing angle). Yet, the same result could be obtained by iterating through multiple initial angle values and then determine which set of machining angles meets the Thin Web Avoidance constraint. If there is more than one set of machining orientations that meets the Thin Web Avoidance constraint, the set of orientations that has the fewest number of machining orientations would be used.

The new method of providing initial angles to VISI is an improvement since it expands the set of possible machining orientation solutions; therefore, it avoids the risk of finding locally optimum solutions. This is particularly important for a rapid prototyping process since it must be assumed that the part geometries could vary widely. In more traditional manufacturing process planning, there are assumptions made about the class of part geometries that will be encountered. For example, machined parts will have been generally designed for machining; hence, perhaps the system will assume that orthogonal setups might work. This assumption is based on the fact that machined parts are primarily designed for

prismatic setups in vices, and other simple fixtures. Of course, in a Rapid Prototyping process, the designer often submits more elaborate and organic part geometries for testing. Hence, any assumptions about part geometry in the hopes of reducing the search space may in fact lead to a non-optimal solution.

To illustrate other part geometries, Figure 4-6 uses dotted arrows to signify an alternative set of machining orientations by giving VISI an initial angle. The solid arrows are the result found using the existing VISI method that does not use an input initial angle.

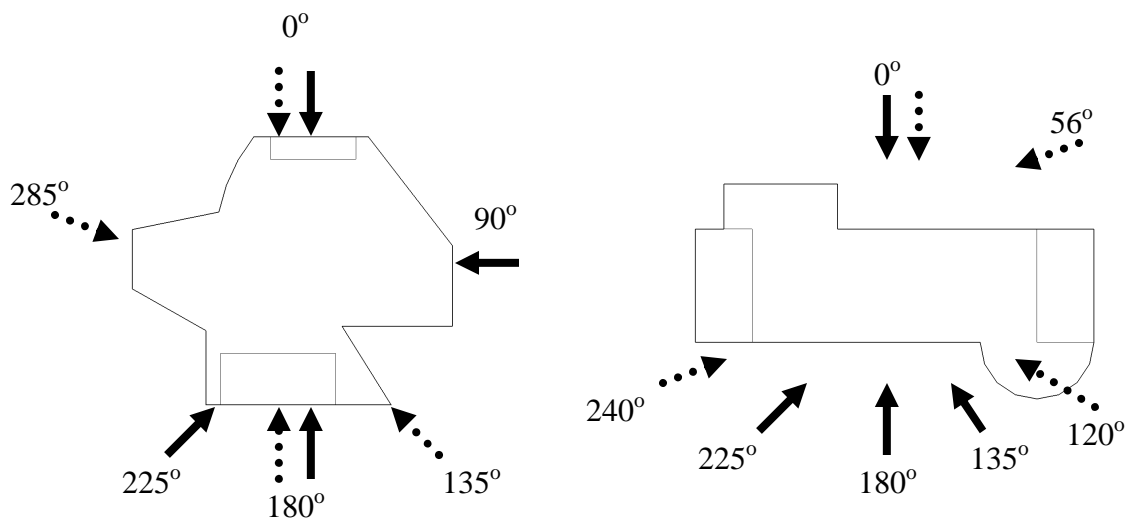

**Figure 4-6: Setup orientations with and without providing an initial angle to VISI**

The parts shown in Figure 4-6 do not show a reduction in machining setups as was seen in Figure 4-3. However, an improved process plan for CNC-RP is not defined as a reduced set of machining orientations. An improved process plan is one that has the minimum total machining time, which is discussed in section 4.1.2.

#### 4.1.2 Tool Accessibility, Selection and Machining Time calculations

Tool accessibility, selection and machining time are important components in a CNC based Computer Aided Process Planning (CAPP) system. Tool selection depends on both tool accessibility and machining time. A tool that cannot access much of the volume of material to be removed may not be a good tool choice. Likewise, a tool that takes a long time to machine the part may not be the best tool to use. In order to avoid poor tool choices in the CNC-RP process plan, the Tool Access Volumes (TAV) method will be used to determine tool accessibility and then the Relative Delta Volume Clearance (RDVC) method will be discussed to determine machining time.

##### Tool Access Volumes (TAV)

The Tool Access Volumes (TAV) calculation will be performed for each potential setup orientation. The TAV calculation is used to find the accessible volume for a given geometry, machining orientation, end mill diameter, and end mill step-down value. Figure 4-7 illustrates the TAV steps to determine the machinable volume for an example pocket geometry. Further details of the original TAV measure can be found in [Lim, 2001], while a modified TAV approach will be used in this thesis.

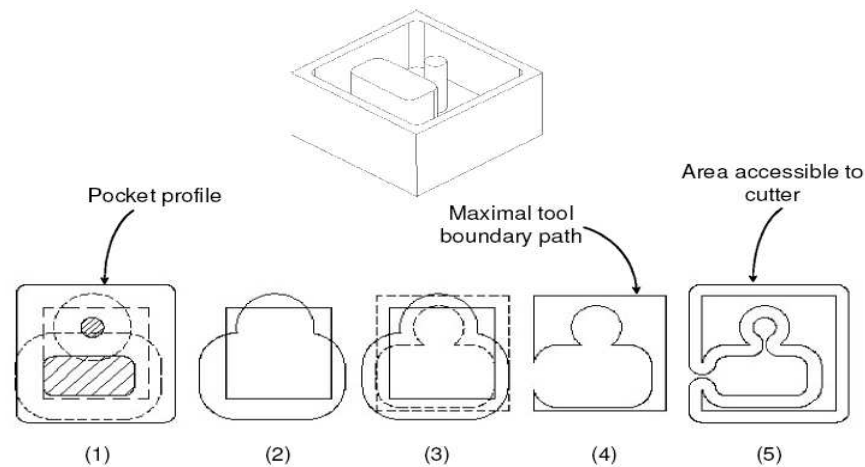
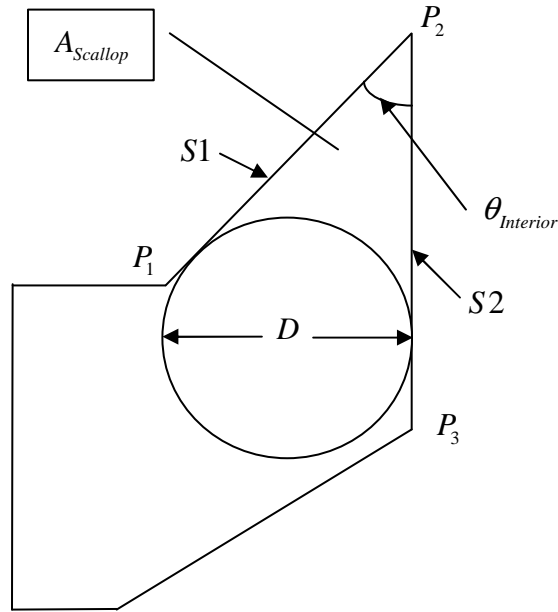

Figure 3. TAV procedure—(1) Offset profiles (broken lines) of the islands and pocket by tool diameter. (2) Intersecting island profiles are united. (3) Offset united islands and pocket profile by tool radius. (4) Unite offset united profiles with sheet plane—the result is the exact boundary path accessible by the tool. (5) Offsetting this tool path by its radius and sweeping it by the feature's range generates the TAV.

**Figure 4-7: Tool Access Volume (TAV) method [Lim 2001]**

In the TAV method, the profile of the pocket geometry is offset based on the diameter of the tool that will be used to machine the pocket. Obviously, the larger the tool, the less access it will have to the part geometry. For complex geometry all aspects of the TAV method would be required; however, the CNC-RP method uses a layer based toolpath strategy, therefore the TAV method can be simplified. In this thesis the intent is to focus on just the “scallop” left in the interior corners of two intersecting polygon segments for each machining layer. This satisfies the major goal in this approach; which is to determine how much material remains after the roughing operations, since this dictates how much material remains for the finishing tool.





**Figure 4-8: Analyzing Polygon segments to find Scallop Area**

To determine the scallop area left by the tool, Figure 4-8 illustrates on a sample pocket geometry, how the calculations are performed. For two segments  $S1$  and  $S2$  on the polygon chains, the interior angle between the two segments can be calculated.

$$S1 = [(P_{2x} - P_{1x}), (P_{2y} - P_{1y})], S2 = [(P_{3x} - P_{2x}), (P_{3y} - P_{2y})] \quad (4.1)$$

$$\theta_{Interior} = \left( \tan^{-1} \left( \frac{S1_y}{S1_x} \right) - \tan^{-1} \left( \frac{S2_y}{S2_x} \right) \right) \quad (4.2)$$

$S1$  and  $S2$  represent the vectors between points  $P_1$ ,  $P_2$  and  $P_3$ . The interior angle  $\theta_{Interior}$  is then calculated by finding the difference between the direction component of each segment's

vector. If the interior angles are less than  $180^\circ$  then the scallop area is calculated based on the interior angle value and the tool diameter value ( $D$ ) which is given by:

$$A_{Scallop} = \left( \frac{(D/2)^2}{\tan\left(\frac{\theta_{Interior}}{2}\right)} \right) - \left| \left( \left( \frac{\pi - \theta_{Interior}}{2} \right) * (D/2)^2 \right) \right| \quad (4.3)$$

The resulting scallop areas are then summed to generate the total area that is not machinable by for that polygonal chain. Therefore, the Tool Accessible Area ( $TAA$ ) can be found by subtracting the part's area from the stock area and adding the scallop area:

$$TAA = A_{Stock} - A_{Part} + A_{Scallop} \quad (4.4)$$

The TAV method was originally applied to a 2 1/2 -D part geometry. Fortunately, CNC-RP uses a layer based machining approach, with the layer thickness determined by the end mill step-down value, which makes the accessible volume (TAV) straightforward. Figure 4-9 illustrates the TAV method for a 3D free-form pocket geometry using a layer based machining operation.

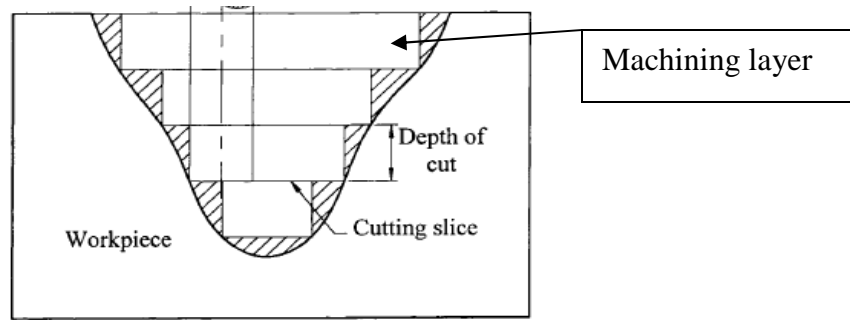
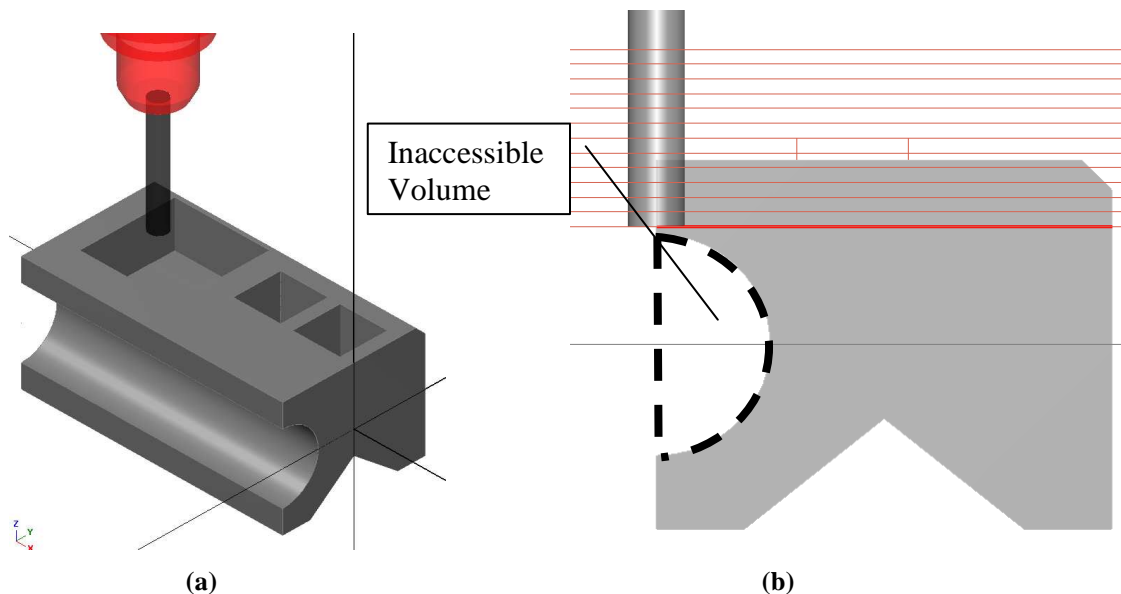

**Figure 4-9: Applying TAV to layer based machining [Lin & Gian, 1999]**

The tool is set to a fixed step-down value (“Depth of cut” as seen in Figure 4-9) based on tool diameter. The TAA can be multiplied by the step-down value ( $SD$ ) for each tool, to generate the Tool Access Volume (TAV) for each machining layer. Each machining layer’s TAV can then be added together to determine the TAV for any geometry at any setup orientation. To determine the total volume of material that can be removed from an orientation, the volumes of each layer starting from the first layer  $L_1$  to the last layer  $L_n$  can be added together:

$$TAV = \sum_{L_1}^{L_n} (TAA * SD) \quad (4.5)$$

One caveat to equation 4.5 is that not every volume is accessible by the machining tool. To illustrate this, Figure 4-10 shows an example part that contains an overhanging feature that does not allow tool access from the positive Z direction to the specified “inaccessible volume”.



**Figure 4-10: (a) Isometric view of part, tool, and inaccessible feature  
(b) View of inaccessible volume from the right side of the part**

The first step to identify inaccessible volumes like these, the STL file of the part is sliced uniformly at a depth equivalent to the step-down for each tool (Figure 4-11).

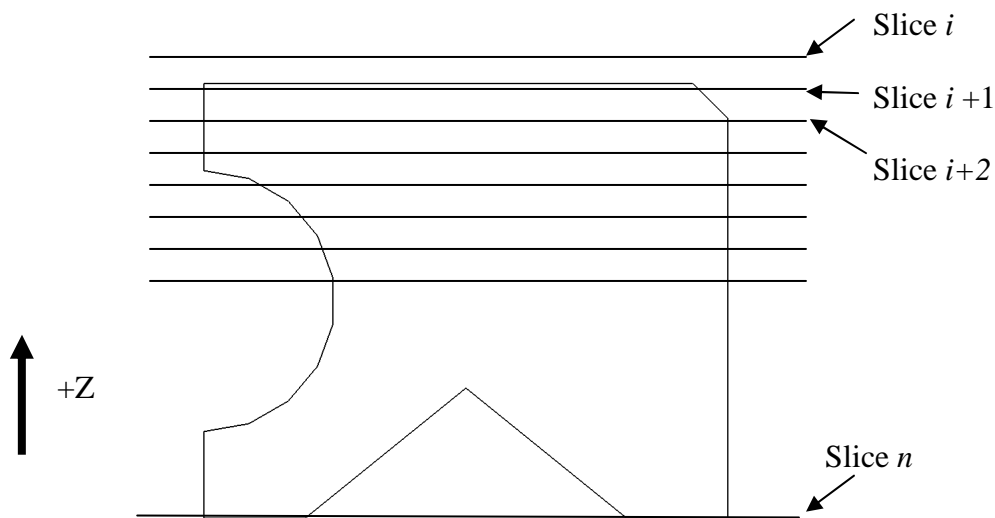

**Figure 4-11: Example part viewed from right side showing slicing**

A Boolean union of slices from the top of the part (Slice  $i$ ) to the maximum depth (Slice  $n$ ) is calculated, whereby all cross sections of the part are successively replaced by a Boolean union of the slice and the slice above it (positive  $z$ -direction). The resulting polygon from the union operation will be the polygon used to evaluate the Tool Access Volume (TAV) at the slice position  $i + 1$ :

$$\text{SliceTAV}_{i+1} = \text{Slice}_i \cup \text{Slice}_{i+1} \quad (4.6)$$

The Tool Access Area (TAA) calculations shown in equation 4.3 and equation 4.4 will only be performed on the new polygon data. The Boolean union operation will not allow for inaccessible volumes caused by overhanging features to be represented in the polygon data used in the TAV analysis.

#### Relative Delta Volume Clearance (RDVC)

The accessible volume of each machining tool provides useful information for determining the total machining time using the RDVC method. [Lim, 2001] RDVC was developed for determining optimal tool selection and sequencing for a multi-tool machining operation. The method not only relates the accessible volume (TAV) to a tool's Material Removal Rate (MRR), but also relates each tool used in a set of machining operations to each other.

For the CNC-RP method, this TAV calculation of equation 4.5 is equal to the volume that the rougher tool can remove and will be designated as " $V_R$ ". It is assumed that the finishing tool used in the CNC-RP process can machine 100% of the remaining volume after rough

machining has been completed. Under this assumption the finishing volume, designated " $V_F$ ", is found by simply multiplying the scallop area (equation 4.3) by the finishing tool's step down value ( $SD_F$ ).

$$V_F = A_{Scallop} * SD_F \quad (4.7)$$

The two volumes  $V_F, V_R$  will be used to illustrate how the total machining time is affected by the size of the finishing and roughing tools. Using a fixed database of tools, the diameters and step-down values for different tools can be retrieved. From this information, volumes removed by the finishing and roughing tools are calculated using equation 4.5 and 4.7. With these two volumes and the Material Removal Rates (MRR) stored for each tool, the RDVC value can be calculated:

$$RDVC = \frac{V_F}{MRR_F} + \frac{V_R}{MRR_R} \quad (4.8)$$

Given a fixed size of finishing tool, the RDVC values will follow the trend shown in Figure 4-12 for different roughing tool diameter values.

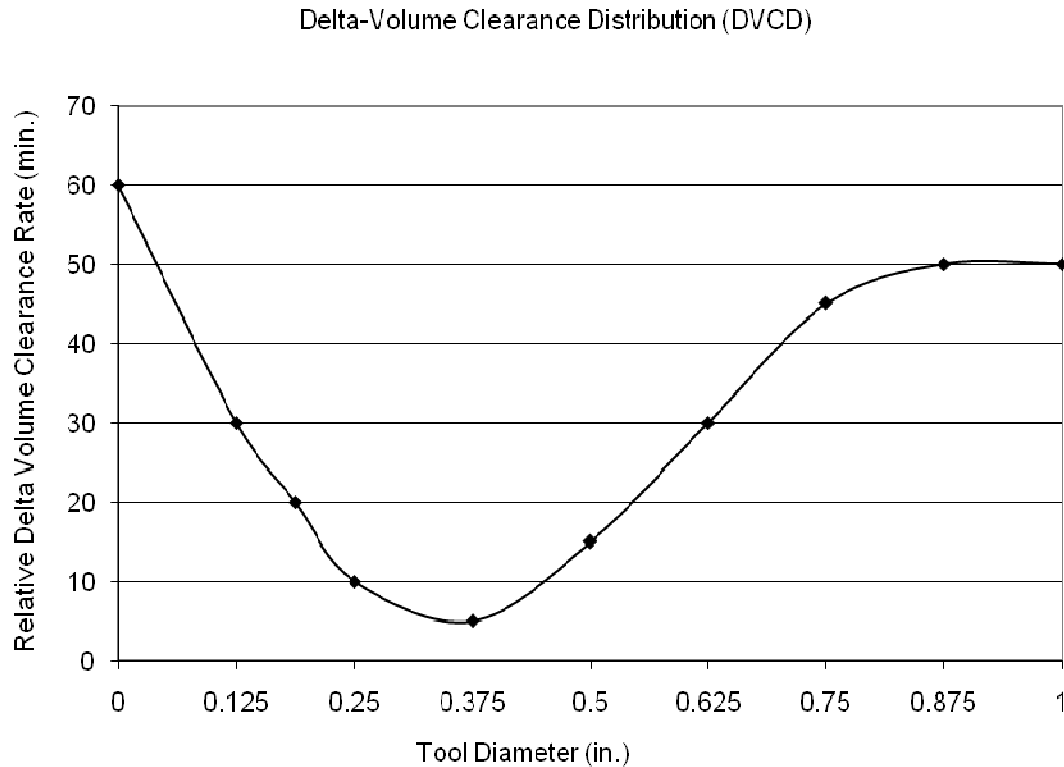

**Figure 4-12: RDVC vs. Tool Diameter [graph based on Lim et. al., 2000].**

The work by Lim et al, uses a similar graph as in 4-12 to demonstrate how the RDVC values change with varying tool diameters. The “Delta-Volume Clearance Distribution” was used to determine the most effective set of tools to machine a part in the least amount of time. The minimum shown in Figure 4-12 represents the solution for shortest total machining time given a fixed set of tool information. To apply the RDVC method to CNC-RP, the tool diameter at the minimum RDVC value (about 5 minutes as shown) would determine the optimum roughing tool diameter (a 0.375” tool would be chosen).

The RDVC method however, was only applied to a 2 ½-D part in previous research; however, CNC-RP uses multiple orientations of 3D geometry. The calculation for a 3D volume at an orientation was discussed in the TAV method, but then the total machining time for a part will be determined by the summation of RDVC times for each orientation in a CNC-RP process. The summation of RDVC times for each machining orientation highlights the advantages of producing more solutions sets by providing the visibility program an initial angle (proposed in 4.1.1). For example, if the VISI program is given an initial angle, it might output a set of machining orientations that could be machined in a shorter amount of time than it could machine a set without an initial angle. Furthermore, a part could be machined in a shorter amount of time by machining at four machining orientations rather than just three:

$$RDVC(\sum[\theta_{init}, \theta_A, \theta_B, \theta_C]) \leq RDVC(\sum[\theta_D, \theta_E, \theta_F]) \quad (4.9)$$

On the left is the VISI solution given an initial angle  $\theta_{init}$ . On the right is an example of a possible solution using the current VISI solution, which only considers the minimum set of machining orientations. This difference in RDVC could be the result of multiple factors; one being the size of tools used for each orientation. For larger roughing tool diameters, the roughing process will finish sooner, yet there will be more volume left that must be machined by the finishing tool.



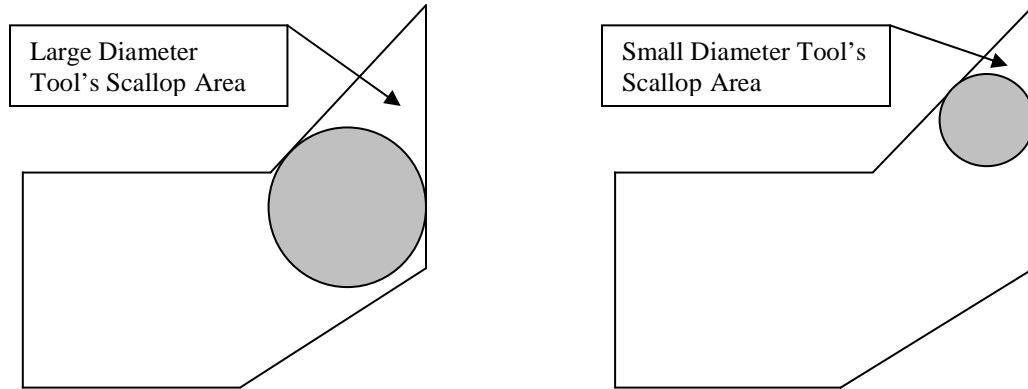

**Figure 4-13: Different Scallop areas left by different sized tools**

For the CNC-RP method, both the roughing and finishing tools are chosen based on stock diameter. The roughing tool diameter is calculated as a percentage of the stock diameter and the finishing tool is chosen as the shortest tool from the library that at least reaches the maximum cut depth for a given orientation. Therefore, larger stock diameters force a larger roughing tool diameter choice and a longer finishing tool and their corresponding machining parameters. For a larger diameter roughing tool, the Material Removal Rate (MRR) may increase due to it removing a larger volume of material for each machining pass, while a longer finishing tool will require a slower feed rate, which will decrease MRR. In the existing CNC-RP process, the MRR values are not used in determining tool. The use of RDVC and TAV improves process planning in the method of this thesis, since factors such as material removal rate, and therefore machining performance can be considered. By using the summation of RDVC values, the optimum set of system variables (the set that machines the part in the shortest amount of time) is not based on just one variable. Tool selection and

machining orientations can be simultaneously varied in order to determine a set of values to use to machine the part in the shortest amount of time.

## 4.2 Genetic Algorithm

Section 4.1 presented a method for calculating total machining time for the CNC-RP process. This method incorporated two major components: 1) how machining orientations can be determined that can safely machine the part geometry and 2) how the machining time per orientation can be determined given the parameters of the tool and the volume of material that it can remove. The minimum total machining time establishes an optimum solution for the CNC-RP process. To determine the minimum total machining time a Genetic Algorithm technique is applied, resulting in the optimum choice of tool size and machining orientation set.

The improvements to the visibility program (VISI) were shown to generate not only the necessary machining orientations (that would completely machine the part), but also how to generate more machining orientation sets by providing an input “initial angle”. Due to the hardware setup for the CNC-RP process, up to 360 different initial angles could be provided to the VISI software program to create 360 unique sets of machining orientations. Each orientation set would include the initial angle  $\theta_{mit}$  and up to  $n$  other orientations:

$$\theta_{mit} \Rightarrow VISI \Rightarrow \{\theta_{mit}, \theta_1, \dots, \theta_n\} \quad (4.10)$$

The TAV method determines the machinable volume for a given tool size at a given orientation of the part geometry. The Relative Delta Volume Clearance (RDVC) was shown to relate the roughing and finishing tools' TAV and Material Removal Rates (MRR). The resulting equation determined the total machining time for a particular machining orientation given MRR and TAV information for each tool.

To apply the machining times calculated with RDVC to the CNC-RP process, the summation of machining times must be taken for all machining orientations output by the VISI program for a given initial angle input.

$$\text{Total Machining Time} = \sum (RDVC(\theta_{init}, \theta_1, \dots, \theta_n)) \quad (4.11)$$

Therefore, there are  $N$  possible solutions given the number of tools  $T_R$  and the 360 different  $\theta_{init}$  values:

$$N = T_R * 360 \quad (4.12)$$

An example of a possible graph of the design problem is shown in Figure 4-14. For different machining orientations, there are different optimum roughing tool diameters (represented by the minimum RDVC times).

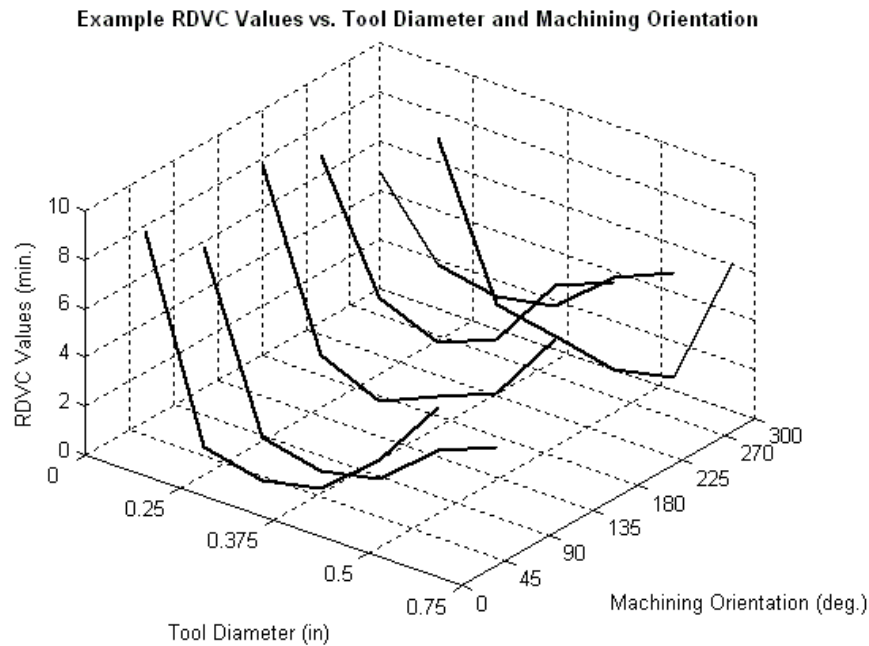

**Figure 4-14: Example graph highlighting multiple local minima**

To address the computational expense of finding the minimum total machining time for every possible machining orientation set for each roughing tool size, a Genetic Algorithm is used. To find an optimal solution using a Genetic Algorithm, the objective of the design problem must first be defined. Therefore, the RDVC function must be minimized for the summation of machining orientations.

Next, the design variables are chosen for the design problem. The technique of providing an initial angle to the VISI program (4.1.1) has been discussed thus far as a means of generating more machining orientation sets. With the application of a Genetic Algorithm, the benefit of generating more machining orientation can be realized. By giving the Genetic Algorithm these initial angles as a design variable, its stochastic search technique can explore many different sets of orientations. The initial angle design variable  $X_1$  can have 360 discrete

values. In Genetic Algorithm terminology, this establishes 0 as the lower bound and 360 as the upper bound for the  $X_1$  variable.

The second design variable  $X_2$  is the diameter of the roughing tool. The diameter of the finishing tool will not be used as a design variable, however, it is still an important part of the search for an optimal solution. The finishing tool size and its other parameters will simply be set to fixed values for all calculations. Table 4-1: Tool Parameters for the  $X_2$  design variable shows the tool parameters that were used to test the Genetic Algorithm method. The finishing tool is listed along with eight choices of roughing tools.

**Table 4-1: Tool Parameters for the  $X_2$  design variable**

<b>Tool</b>	<b>Diameter (in) "D"</b>	<b>Step-Down (in) "SD"</b>	<b>Feed Rate (in/min) "FR"</b>
Finishing	0.1875	0.003	150
0	0.25	0.02	120
1	0.25	0.02	110
2	0.375	0.03	110
3	0.375	0.03	100
4	0.5	0.04	70
5	0.5	0.04	55
6	0.75	0.06	30
7	0.75	0.06	25

Now that each design variable is determined, the objective function can be formulated. Since the goal of the Genetic Algorithm is to determine a minimum machining time, the RDVC function (equation 4.8) is derived in terms of the two design variables: the initial angle  $X_1$  and the roughing tool diameter  $X_2$ .

$$f(X_1, X_2) = \begin{cases} X_1 \Rightarrow VISI \Rightarrow \theta[n] \\ \min \left( \sum_i^n \left( \frac{TAV(\theta[i], D_F)}{(SD_F)(D_F)(FR_F)} + \frac{TAV(\theta[i], X_2)}{(SD_{X_2})(X_2)(FR_{X_2})} \right) \right) \end{cases} \quad (4.13)$$

In equation 4.13 the Fitness function  $f(X_1, X_2)$  is in terms of the initial machining orientation  $X_1$  that is sent to the VISI program and the diameter of the roughing tool  $X_2$ . Before the fitness function can be evaluated, The Step-down “ $SD$ ” and Feed-Rate “ $FR$ ” are unique to each tool, and subscripts  $F$  and  $X_2$  represent the finishing and roughing tools, respectively. The notation “ $TAV()$ ” in equation 4.13 denotes a function which calculates the Tool Access Volume which depends on the machining orientation and tool diameter. Upon further inspection of the Fitness function, the fitness value is in units of time (minutes due to the Feed-Rate values used).

To test the Genetic Algorithm problem formulation, the Fitness function is evaluated using common Genetic Algorithm methodologies. First, the algorithm is initialized by randomly generating values for each design variable, representing the initial Population. This Population is then evaluated using the Fitness function, and a Tournament Selection process determines the fittest two individuals from the population. These two members undergo a Crossover and Mutation routine, manipulating their “genes” to create an offspring. This offspring represents a new solution and is stored to create the second Population. The child solution can then be evaluated by testing it in the Fitness function. The process then repeats

until the fittest solution is found. In this application, the fittest roughing tool size, and set of machining orientations determine the optimal solution – the minimum total machining time.

### **4.3 Implementation**

The previous section discussed how a Process Planning algorithm for CNC-RP can benefit from using a Genetic Algorithm. The design variables were determined to be the initial angle input to VISI ( $X_1$ ) and the roughing tool diameter ( $X_2$ ). A Fitness function for the Genetic Algorithm was also formulated, with the fittest solution representing the set of machining orientations and the roughing tool diameter that could machine the part in the shortest amount of time.

The standard Genetic Algorithm method discussed in section 4.2 was used to test the Genetic Algorithm problem setup. To handle the data types for each design variable, a real-valued encoding scheme was used. To limit the possible solutions to common tool sizes a type of “pointer” system was used. [Ghasemi, et al. 1997] The actual values for the  $X_2$  variable were assigned integer values that “pointed” to the actual diameter value for the machining tool. At the same time that the diameter value was being retrieved, other tool information could be collected that was required by the Fitness function. The machining orientations for the  $X_1$  variable were stored as integer values as well. For testing purposes, the increment value of each initial angle was increased from  $1^\circ$  to  $15^\circ$  using the same pointer technique used to encode the roughing tool diameters.

Sample code was used from the *Kanpur Genetic Algorithms Laboratory*. [Deb, 2001] The sample code was modified for this application and recoded in C++. The algorithm was then tested on optimization test problems using two design variables. Problems like the Six-hump camel back function that have multiple local minima were tested, and the global minima were found with speed and accuracy. The variables went through the Simulated Binary Crossover routine developed by [Deb, et al. 1995]. Also, a Polynomial Mutation method was used to handle the real valued variables [Deb, et al. 1995]. These Crossover and Mutation routines use two values  $\eta_C$  for Crossover, and  $\eta_M$  for Mutation.  $\eta_C$  effectively controls Crossover in such a way that for larger values, there is a higher probability that the child solution will be closer to the value of the parents.  $\eta_M$  provides a similar functionality, except since it is applied to Mutation, it has more a more local affect on the child solution.

#### Implementation Results:

The necessary functions for the Tool Access Volume method, and the VISI program were built into a single Microsoft Visual Studio 2005 executable project. Testing was performed using a 32-bit PC running Windows XP on an Intel Pentium D 3.0 GHz CPU with 3.5 Gb of RAM.



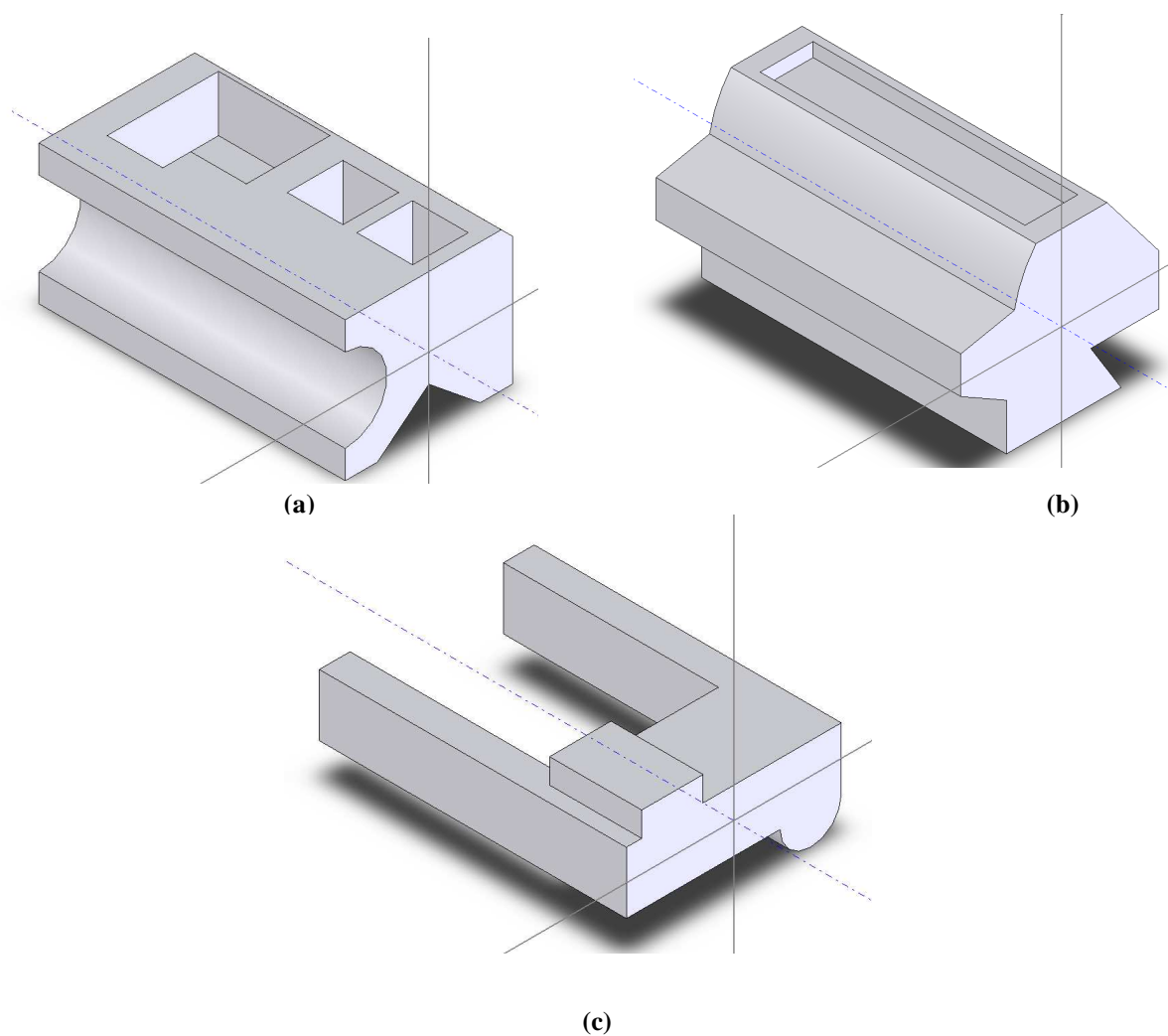

Figure 4-15: Test parts

Table 4-2: Test Parts Dimensions\*

Test Part	Length (in)	Width (in)	Height (in)
(a)	5.5	2.75	2.5
(b)	5.5	3	3.5
(c)	5	3.5	1.5

\*All parts fit inside a 4" diameter stock

The following variables were used to generate the summary of results shown in Table 4-3.

- Number of discrete  $X_1$  values (angle value in degrees): 24
- Number of  $X_2$  values (roughing tool diameters): 8
- Tournament Size: 10
- Maximum number of generations: 20
- Population Size: 30
- Crossover Probability: 0.95
- Mutation Probability: 0.5
- $\eta_c$ : 2 (crossover control coefficient)
- $\eta_m$ : 100 (mutation control coefficient)

**Table 4-3: GA Results for 3 test parts showing Fitness and Design Variable values**

Genetic Algorithm Results						
		Gen. 0	Gen. 1	Gen. 2	Gen. 3	Gen. 4
<b>Test Part (a)</b>	<i>Fitness (min.)</i>	72.36	65.42	63.94		
	<i>X1 (deg.)</i>	135	135	135		
	<i>X2 (in.)</i>	0.5	0.375	0.375		
<b>Test Part (b)</b>	<i>Fitness (min.)</i>	47.42	41.39	41.38		
	<i>X1 (deg.)</i>	225	135	135		
	<i>X2 (in.)</i>	0.5	0.5	0.5		
<b>Test Part (c)</b>	<i>Fitness (min.)</i>	78.27	76.96	67.6	67.35	67.25
	<i>X1 (deg.)</i>	30	135	180	180	180
	<i>X2 (in.)</i>	0.5	0.5	0.5	0.5	0.5

The Genetic Algorithm results show steady convergence toward the minimum total machining time. With each generation having a population of 30 members, Part (c) took the most number of iterations before it converged in generation four (starting with index 0). Each test part had at least one change in a design variable choice after the first generation's calculations. Only Part (c) changed its choice of design variable X1 (the initial angle provided to VISI) after the first generation.

**Table 4-4: Results for CNC-RP with 3 test parts**

	<b>Test Part (a)</b>	
	<b>Current CNC-RP Approach</b>	<b>Proposed Approach</b>
<b>Machining Orientations (deg.)</b>	0	0
	45	135
	135	261
	225	
	261	
<b>Roughing Tool Size (in.)</b>	0.75*	0.375
<b>Total Machining Time (min.)</b>	122.542	63.94

	<b>Test Part (b)</b>	
	<b>Current CNC-RP Approach</b>	<b>Proposed Approach</b>
<b>Machining Orientations (deg.)</b>	0	0
	90	135
	180	180
	225	285
<b>Roughing Tool Size (in.)</b>	0.75*	0.5
<b>Total Machining Time (min.)</b>	53.44	46.97

	<b>Test Part (c)</b>	
	<b>Current CNC-RP Approach</b>	<b>Proposed Approach</b>
<b>Machining Orientations (deg.)</b>	0	0
	135	45
	180	180
	225	315
<b>Roughing Tool Size (in.)</b>	0.75*	0.5
<b>Total Machining Time (min.)</b>	79.41	67.25

\*CNC-RP uses a 0.75" tool for every part due to stock diameter

Table 4-4 shows three different test parts and variables that are important for the CNC-RP process. The resulting orientations from both CNC-RP and the method of this thesis are illustrated in Figure 4-16: Orientations for Proposed Approach are dotted and values are given. Compare to current CNC-RP orientations.

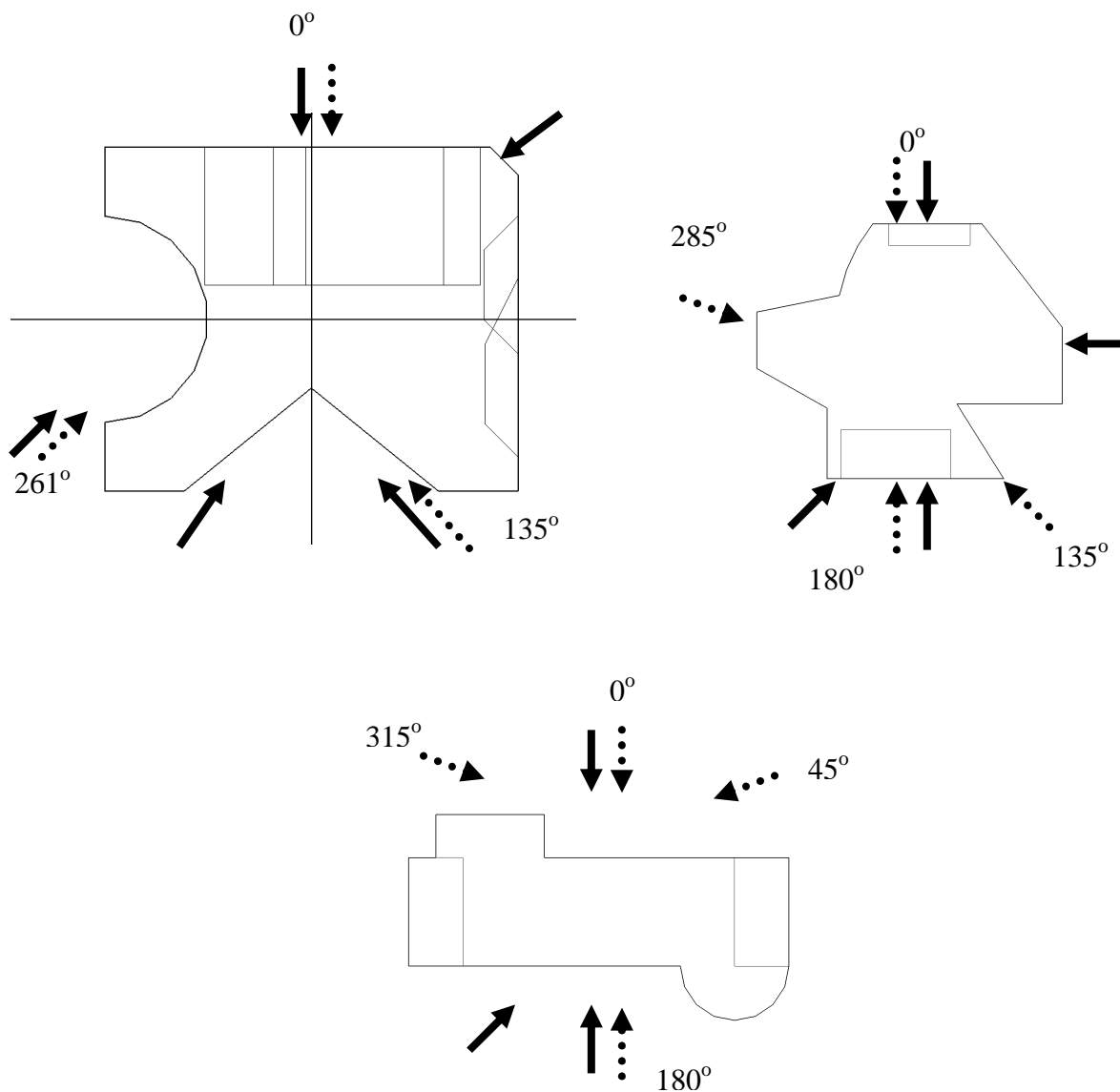

**Figure 4-16: Orientations for Proposed Approach are dotted and values are given. Compare to current CNC-RP orientations.**

Part (a) shows that using the new approach discussed in this thesis will provide a total machining time that is 52% of the current machining time. This results from a smaller tool being used, and fewer machining orientations. Part (b) and part (c) had less significant total time savings at 13% and 15% respectively. The results show that the design problem was

properly formulated because the Genetic Algorithm method returned a reduced total machining time. In addition to reducing the total machining time, a method for choosing tool sizes, and machining orientations is provided. In chapter five, a discussion is provided to explain why it is important to determine the tool sizes and machining orientations at the same time.

## 5 Discussion, Future Work, and Conclusions

### 5.1 Discussion

The parts used in the Genetic Algorithm implementation of chapter four were designed to specifically test the problem setup. Minimizing the Relative Delta Volume Clearance (RDVC) equation was established in Chapter four as the objective that should result in a minimum total machining time for the CNC-RP process. The RDVC equation (Equation 4-13) was derived in terms of the two design variables used in the Genetic Algorithm used for the Genetic Algorithm implementation.

Specifically, the geometric *properties* of the parts were intentionally designed into the three test parts (Figure 4-15). The first geometric property was “flatness” as illustrated in Figure 4-15 (c), which has a width that is more than twice its height (see Table 4-2). This flatness property was used to test the  $X_2$  design variable – the roughing tool’s diameter. With basic machining experience, a human could examine a part like the one in Figure 4-15 (c) and make an intelligent roughing tool choice based on the fact that a very large tool could quickly machine the round stock to the wide face on the top of the part. Without many features on the part to machine in and around, a large diameter roughing tool could perform what is often termed as a “hogging” operation. For the parts shown in Figure 4-15 (a) and Figure 4-15 (b) a large diameter tool would not be able to machine many of the smaller features that those two parts have. If a large diameter tool was used, a large amount of volume would be left for the finisher tool to machine.

The second geometric property designed into the test parts is “orientation specific accessibility”. This property can be seen where there are features that a tool can only access if it is nearly normal to that feature. This idea is illustrated on a right side view of Figure 4-15 (b):

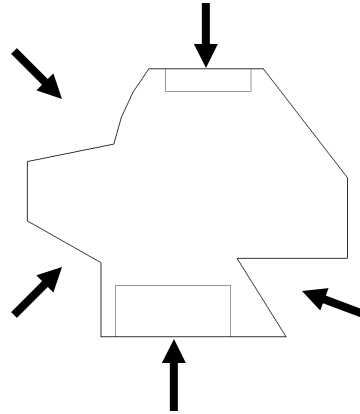

**Figure 5-1: Features affecting tool accessibility**

Figure 5-1 shows five different features on the part that the Visibility (VISI) program would determine have fewer number of orientations from which they can be machined. These features not only affect “how visible” a part is, but they also affect tool choice (Figure 5-2).

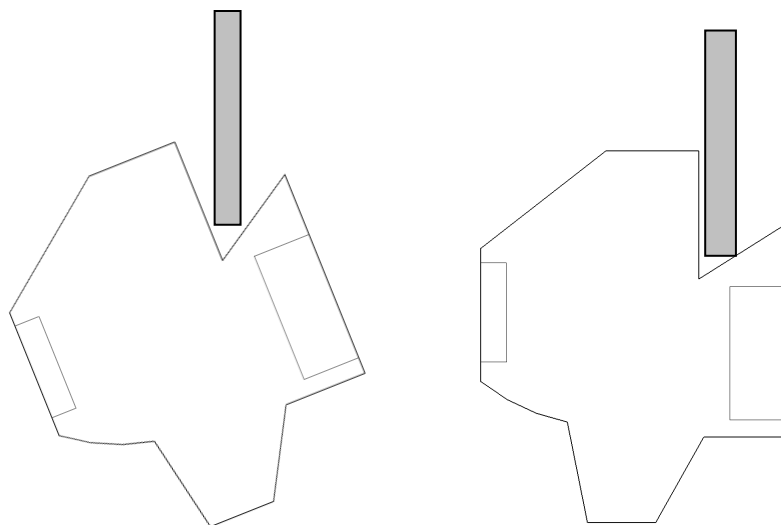

**Figure 5-2: Machinability based on machining orientation**

Previous research has been directed to situations like that seen in Figure 5-2: Machinability based on machining orientation, in order to determine the part's "Machinability" [Li and Frank, 2006]. By including the tool size (design variable  $X_2$  in the Genetic Algorithm formulation) and different machining orientations (design variable  $X_1$ ) the best solution (shortest machining time) is driven by machining orientation and machining tool size. The results summarized in Table 4-3 show why the combination of tool size and orientation results in a shorter total machining time. In Table 4-3 (a) the largest change in machining time vs. the current CNC-RP method is shown. Given the orientations, there are three angles that are the same between the two approaches; however, the number has decreased by two. The reduction in total machining orientations might explain the reduction in total time. However, the material removal rate (MRR) of the 0.375" tool is 1.2375 in<sup>3</sup>/min and for the 0.75" tool it is 1.35in<sup>3</sup>/min; these two variables seem to conflict. It is interesting that the number of machining orientations can be reduced while the MRR of the roughing tool is lowered, and the total machining time can be significantly shorter. It appears that it is not just the machining tool size or set of machining orientations alone that determines the optimal set of machining parameters for the Computer Aided Process Plan (CAPP) for the CNC-RP process. The other two parts show less significant savings in total machining time, however, the values for the tool size and machining orientations are not very different from the CNC-RP set.

The ambiguity of results of changing just one variable is what originally drove this research to the use of a Genetic Algorithm. As tool size changes, the set of machining orientations may take longer to machine, and vice versa. If the problem was to be solved for the test part,



there would be 96 possible solutions to be evaluated. While this is not a significant computation expense, the point of the research was to show that the problem setup was done correctly so that further complexity could be added to the design problem. This thesis is not suggesting that this Genetic Algorithm method will generate the result in the shortest amount of time. More appropriate methods may exist that work better for this application, but the results show that the problem was formulated properly since it finds better results than the old CNC-RP method for each test part. Furthermore, the results show that the total machining time is not affected by just the tool size or machining orientation set alone, it is affected by both variables.

As seen in Table 4-4, the genetic algorithm slowly reduced the total machining time over at most 5 generations. Furthermore, each design variable converged differently for each test part. For only the first part, the choice of the initial angle provided to VISI stayed the same for all generations (design variable  $X_1$ ). For the other two parts, the initial angle choice changed multiple times after each generation before converging on the best solution. For design variable  $X_2$ , the tool diameter, it resulted in different values for different generations also, and only test part (b) did not have a change in tool size. Test part (c) does not show a change in the size of the tool diameter in Table 4-4, however, there were two feed-rates for this size of tool. From generation two to generation three, neither the set of machining angles nor the tool size seems to change, but looking further at the results, it was found that the second tool with a faster feed-rate was chosen, resulting in the smaller Fitness value.

## 5.2 Future Work

There are many different opportunities to advance this research. Certainly, no attempt was made here to show that the chosen Genetic Algorithm technique was the best choice for this design problem. However, the research establishes a good problem formulation that provides the basis for other parameters related to CNC-RP to be added. For example, the design problem could allow dynamic tool choices for every orientation instead of one tool for each set of orientations. The number of design variables could easily be expanded to handle multiple tools instead of just one which was used to find the roughing tool size.

One useful modification that falls outside of the Genetic Algorithm problem is in the determination of the Tool Access Volumes (TAV). For some features that are more complex than those shown in the test parts, a more involved calculation of the actual accessible volume would be required. A measure of the actual accessible volume also requires knowledge of the machinability of certain features. The addition of machinability to the volume calculation would provide an even more accurate representation of the TAV for each machining orientation .

The set of orientations are determined by rotating about the 4<sup>th</sup> axis due to the CNC-RP setup. However, this is done after the part has been centered about the X, Y, and Z axes. Algorithms to determine a more optimal axis of rotation could be added as another design variable.

Finally, the machining times determined by the RDVC calculation may not be not be achieved when the part is machined. Due to machining toolpath types used in commercial CAM packages, there are many different reasons why the tool will not operate at the full feed-rate used in determining the RDVC value. The actual feed-rates, accelerations, and decelerations of the machining tool could be added to give a more accurate result of the total machining time.

### **5.3 Conclusions**

Minimum total machining time should be used as the objective in determining roughing tool size and the set of machining orientations for a CAPP for CNC-RP because it results in an optimum set of system variables. Applying the RDVC equation to each machining orientation set returned from a given initial angle, a relationship between total machining time, rougher tool size and the necessary machining orientations is established. Implementing a Genetic Algorithm can determine the values for each of these variables which establishes the fundamental components for a CAPP method for CNC-RP that is independent of part geometry. This thesis provides a first step toward making the CNC-RP subtractive rapid prototyping process more cost-effective by reducing the overall processing time to machine a part.

## Acknowledgements

To Dr. Matthew C. Frank for his constant help, and patience in developing this thesis, for his acceptance of new ideas, for his ever-present advice, and for the day-to-day help he has given me to establish my professional career. I can't thank you enough.

To Dr. Eliot Winer who was instrumental in implementing a Genetic Algorithm in this thesis, and for his time and professional advice as I learned many new things with his group at the Virtual Reality Applications Center (VRAC). And also to Vijay Kalivarapu, Eliot's student who helped me implement much of the work in this thesis for Genetic Algorithm.

To Dr. Frank Peters for providing his help in making my committee well rounded as he brings important professional experience and perspective from the manufacturing industry.

To all the co-workers that I have had the pleasure of interacting with as a Research Assistant over the past 2 years, thanks Ye Li, Wutthigrai, Xiaoming, and Joe.

## References

Armarego, E. J. A.; Smith, A. J. R.; and Wang, J. (1993) “Constrained optimization strategies and CAM software for single-pass peripheral Milling”, *International Journal of Production Research*, 31:9, 2139 – 2160.

Arora, J.S.; Huange, M.W.; and Hsieh, C.C. (1994). “Methods for optimization of nonlinear problems with discrete variables: A review”, *Structural optimization*, 8:2-3, 69-85.

Bala, M.; Change, T.C. (1991). “Automatic cutter selection and optimal cutter path generation for prismatic parts”, *International Journal of Production Research*, 29:11, 2163 – 2176.

Balasubramaniam, Mahadevan; Joshi, Yogesh; Engels, Daniel, Sarma, Sanjay; and Shaikh, Zafar (2001) “Tool selection in three-axis rough machining”, *International Journal of Production Research*, 39:18, 4215 – 4238.

Boonsuk, W. (2005). “Automated fixture design for a rapid machining process”, Thesis M.S., Iowa State University, IMSE.

Bose, Utpal (1999). “A Cooperative Problem Solving Framework for Computer-Aided Process Planning”, *Proceedings of the 32<sup>nd</sup> Hawaii International Conference on System Sciences*.

Cay, F.; Chassapis, C. (1997). “An IT view on perspectives of computer aided process planning research ”, *Computers in Industry*, 34, 307-337.

Chen, Y.H; Hu, Y.N. (1999). “Implementation of Robot System for Sculptured Surface Cutting. Part 1. Rough Machining”, *The International Journal of Advanced Manufacturing Technology*, 15:624-629.

Chen, Y.H; Song, Y. (2001). “The development of a layer based machining system”, *Computer-Aided Design*, 33:331-342.

Chen, Y.-T.; Lin, C.-Y. (2000). “Determination of optimum design spaces for topology optimization”, *Finite Elements in Analysis and Design*, 36:1-16.

Chen, Z.; Dong, Z.; and Wickers, G.W. (2003). “Automated surface subdivision and tool path generation for 3 1/2 1/2 axis CNC machining of sculptured parts”, *Computers in Industry*, 50:319-331.

Cheng, W.; Fuh, J.Y.H; Nee, A.Y.C; Wong, Y.S.; Loh, H.T.; and Miyazawa, T.(1995). “Multi-objective optimization of part-building orientation in SLA”, *Rapid Prototyping Journal*, 1:4, 12-23.

Choi, S.H.; Yoon, K.-C (2001). “A Design Method of an Automotive Wheel-Bearing Unit With Discrete Design Variables Using Genetic Algorithms”, *Journal of Tribology*, 123:181-187.

Chu, X.N; Tso, S.K.; and Tu, Y.L. (2000). “A Novel Methodology for Computer-Aided Process Planning”, *The International Journal of Advanced Manufacturing Technology*, 16:714-719.

Chung, C.; Peng, Q. (2004). “The selection of tools and machines on web-based manufacturing environments”, *International Journal of Machine Tools & Manufacture*, 44:317-326.

Deb, K.; Agrawal, R.B. (1995). “Simulated Binary Crossover for Continuous Search Space”, *Convenor, Technical Reports, Dept. of Mechanical Engineering, Indian Institute of Technology, Kanpur, UP, India.*

Deb, K. (2001). *Kanpur Genetic Algorithms Laboratory.*  
<http://www.iitk.ac.in/kangal/codes.shtml>. Accessed Feb. 19, 2008.

D'Souza, R. M. (2006). “On setup level tool sequence selection for 2.5-D pocket machining”, *Robotics and Computer-Integrated Manufacturing*, 22:256-266.

Frank, M.C. (2003). “The development of a rapid prototyping process using numerical controlled machining.” *PhD Dissertation. University Park, PA: Dept. of Industrial and Manufacturing Engineering, Pennsylvania State Univ.*

Frank, M.C., Wysk, R.A., and Joshi, S.B. (2004). “Rapid Planning for CNC Machining – A New Approach to Rapid Prototyping”, *Journal of Manufacturing Systems, SME, Volume 23, No. 3, pp. 242-255.*

Frank, M.C., Wysk, R.A., and Joshi, S.B. (2006). “Determining Setup Orientations from the Visibility of Slice Geometry for Rapid CNC Machining”, *Journal of Manufacturing Science and Engineering, Transactions of the ASME, Vol. 128, No. 1, pp. 228-238.*

Ghasemi, M.R.; Hinton, E.; and Wood, R.D (1999). “Optimization of Trusses using genetic algorithms for discrete and continuous design variables”, *Engineering Computations*, 16:3, 272-301.

Gian, R.; Lin, T.W; and Lin, A.C. (2003). “Planning of tool orientation for 5 axis cavity machining”, *Int J Adv Manuf Technol* 22:150-160.

Hur, J.; Lee, K.; Zhu-hu; and Kim, J. (2002). “Hybrid rapid prototyping system using machining and deposition”, *Computer-Aided Design*, 34:741-754.

Kochan, D.; Kai, C.C.; and Zhaohui, D. (1999). “Rapid Prototyping issues in the 21st century”, *Computers in Industry*, 39:3-10.

Krimpenis, A.; Vosniakos, G.-C. (2002). “Optimisation of Multiple Tool CNC Rough Machining of a Hemisphere as a Genetic Algorithm Paradigm Application.”, *Int J Adv Manuf Technol*, 20:727-734.

Lee, Y. S., Choi, B. K. and Chang, T. C. (1992) “Cut distribution and cutter selection for sculptured surface cavity machining”, *International Journal of Production Research*, 30:6, 1447 – 1470.

Leiserson, C. E., Cormen, T. H. and Rivest, R. L. (1995). *Introduction to algorithms*, MIT Electrical Engineering and Computer Science Series (MIT Press) ISBN: 0-262-03141-8.

Li, Y.; Frank, M.C. (2006). “Machinability Analysis for 3-Axis Flat End Milling”, *Transactions of the ASME*, 128:454-464.

Li, Y.; Frank, M.C. (2007). “Computing non-visibility of convex polygonal facets on the surface of a polyhedral CAD model”, *Computer-Aided Design*, 39:732-744.

Lim, T., Corney, J., Ritchie, J. M. and Clark, D. E. R. (2001). “Optimizing tool selection”, *International Journal of Production Research*, 39:6, 1239 -1256.

Lin, A.C.; Gian, R. (1999). “A multiple-tool approach to rough machining of sculptured surfaces”, *Int J Adv Manuf Technol*, 15:387-398.

Liou, F.; Slattery, K.; Kinsella, M.; Newkirk, J.; Chou, H.-N.; and Landers, R. (2007). “Applications of a hybrid manufacturing process for fabrication of metallic structures”, *Rapid Prototyping Journal*, 13:4, 236-244.

Pine, Joseph B. II (1993). “Mass Customization, The New Frontier in Business Competition”, Harvard Business School Press.

J. M. Pinilla, J. Kao, and F. B. Prinz, (1998). “Process Planning and Automation for Additive-Subtractive Solid Freeform Fabrication”, *Proceedings of the Solid Freeform Fabrication Symposium*, University of Texas at Austin.

Quinsat, Y.; Sabourin, L. (2006). “Optimal selection of machining direction for three-axis milling of sculptured parts”, *Int J Adv Manuf Technol*, 27:1132-1139.

Sadaiah, M.; Yadav, D.R.; Mohanram, P.V.; and Radhakrishnan, P. (2002). "A Generative Computer-Aided Process Planning System for Prismatic components", *Int J Adv Manuf Technol*, 20:709-719.

Sun, G.; Sequin, C.H.; Wright, P.K. (2001). "Operation decomposition for freeform surface features in process planning", *Computer-Aided Design*, 33:621-636.

Vanderplaats, Garret N. (2001). "Numerical Optimization Techniques for Engineering Design",  
3rd edition 2001, Vanderplaats Research and Development Inc.

Wu, S.-J.; Chow, P.-T.(1995). "Steady state Genetic Algorithms for Discrete Genetic Algorithm of Trusses", *Computers & Structures*, 56:6, 979-991.

Yao, Z.; Gupta, S.K.; and Nau, D.S. (2001). "A Geometric Algorithm for Finding the Largest Milling Cutter", *Journal of manufacturing Processes*, 3(1):1-16.